

# CONTINUOUS MIXED FLOW GRAIN DRYERS

Operating and Maintenance Instructions

© 1990,1993,1995 Kentra Grain Systems Limited - All Rights Reserved





# Operating and Maintenance Instructions

---

This Manual has been carefully prepared to give you a better understanding of your KENTRA Grain Dryer. Please read it carefully as it provides useful information on Installation, Use and Maintenance.

<b>The Supply of Machinery (Safety) Regulations 1992 (S.I. 1992/3073)</b>	
Manufacturer	<b>Kentra Grain Systems Limited Station Road Kirk Hammerton YORK YO5 8DQ England</b>
Dryer Model	
Supply Voltage	<b>400/3/50</b>

The above machine when installed and commissioned correctly by the manufacturer, or his approved agent, will conform with the provisions of the Supply of Machinery (Safety) Regulations 1992 (S.I. 1992/3073)

In order to ensure, so far as is practical, that the Equipment is safe and without risk to health when properly used, regular servicing and inspection should be carried out in accordance with the details given in this Manual or available on request. It is expected that users will employ safe working practices and will observe any related legal requirements when installing, operating, maintaining and overhauling. The attention of U.K. users is drawn to the Health and Safety at Work Act 1974.

Date of Purchase	
Installation Date	
Name	Barry J. Higginbottom (Director) 

# Operating and Maintenance Instructions

---

## Copyright

The Kentra manuals are copyrighted and all rights reserved. The manuals may not, in whole or part, be copied, photocopied, reproduced, translated, or reduced to an electronic medium of machine readable form without prior consent in writing from Kentra Grain Systems Limited.

*Kentra Grain Systems Limited grants you a nonexclusive, personal license to use the software provided on the E<sup>2</sup>PROM plug-in memory pack with the dryer control panel. You may not transfer, sell, lease or distribute copies of the software on the memory pack to others. You acknowledge that the KENTRA software is copyrighted by Kentra Grain Systems Limited and is proprietary to Kentra Grain Systems Limited. Kentra Grain Systems Limited retains title and ownership of the KENTRA software.*

YOU MAY NOT MODIFY, ALTER, TRANSLATE, DISASSEMBLE OR DECOMPILE THE KENTRA SOFTWARE OR DOCUMENTATION OR ANY COPY, IN WHOLE OR IN PART.

# Operating and Maintenance Instructions

---

## Table of Contents

<b>1.</b>	<b>INTRODUCTION</b>	1
a.	Type 20,25,40 & 50 Grain Dryers	1
b.	Reserve Holding Section	1
c.	Drying Column	1
d.	Furnace Unit	1
e.	Cooling Section	2
f.	Discharge Unit	2
g.	Dryer Control Panel	2
i.	SYSTEM MONITOR	4
	(1) GRAIN FEED FAILURE	4
	(2) GRAIN TEMPERATURE OVERHEAT	4
	(3) HOT AIR TEMPERATURE OVERHEAT	4
	(4) BURNER LOCKOUT (Flame Failure)	4
	(5) DISCHARGE HOPPER BLOCKED	4
	(6) ELECTRIC MOTOR OVERLOAD	4
	(7) MUTE AUDIBLE ALARM	4
ii.	TEMPERATURE CONTROL	5
iii.	TEMPERATURE MONITOR	5
iv.	DISCHARGE SPEED CONTROL (DMC30™ models only)	5
v.	BURNER CONTROL	5
h.	Maximum Air and Grain Temperatures	5
<b>2.</b>	<b>PRE-COMMISSIONING CHECKS</b>	7
b.	Electrical Inspection (After Mains Power is Applied)	8
c.	Fuel Supply Inspection	8
d.	Discharge Unit Inspection	10
e.	Dryer Inspection	10
<b>3.</b>	<b>DRYER OPERATION</b>	17
a.	Filling the Dryer	17
b.	Starting with Wet Grain	17
c.	Re-starting a Full Dryer	18
d.	Dryer Shutdown	18
<b>4.</b>	<b>AUTO-DISCHARGE CONTROL</b>	19
a.	Description	19
b.	Auto-Discharge Control Set-Up Procedure	19
c.	Automatic Discharge Control Fault Finding	20
<b>5.</b>	<b>FAULT FINDING</b>	20
a.	Fault Protection and Shutdown Procedure	20
b.	Electrical Fault Finding Procedure	21
c.	Burner Lockout	22
d.	Fault Finding Chart	23
<b>6.</b>	<b>HEALTH &amp; SAFETY CONSIDERATIONS</b>	25
a.	Noise Hazard	25
b.	Electrical Hazard	25
c.	Fire Hazard	26
<b>7.</b>	<b>LUBRICATION</b>	27
a.	Discharge Drive Variator	27
b.	Worm Gear Unit	28

# Operating and Maintenance Instructions

---

## Table of Contents

<b>8.</b>	<b>PRE SEASON MAINTENANCE .....</b>	<b>28</b>
<b>9.</b>	<b>POST SEASON MAINTENANCE .....</b>	<b>29</b>

# Operating and Maintenance Instructions

---

## Tables

<b>Table I</b> - Maximum Air & Grain Temperatures .....	7
<b>Table II</b> - Dryer Standard Capacity .....	11
<b>Table III</b> - Recommended Lubricants, Variator .....	27
<b>Table IV</b> - Recommended Lubricants, Worm Gear Units .....	28
<b>Table V</b> - Key to <b>Figure 9</b> .....	33
<b>Table VI</b> - Key to <b>Figure 10</b> .....	35
<b>Table VII</b> - Key to <b>Figure 11</b> .....	37
<b>Table VIII</b> - Key to <b>Figure 12</b> .....	39
<b>Table IX</b> - Key to <b>Figure 13</b> .....	41

# Operating and Maintenance Instructions

---

## Figures

<b>Figure 1</b> Dryer Control Panel Layout . . . . .	3
<b>Figure 2</b> Chain Drive Rotation Direction . . . . .	10
<b>Figure 3</b> Dryer Capacity Curve . . . . .	12
<b>Figure 4</b> Discharge Rates 20 Series Dryer . . . . .	13
<b>Figure 5</b> Discharge Rates 25 Series Dryer . . . . .	14
<b>Figure 6</b> Discharge Rates 40 Series Dryer . . . . .	15
<b>Figure 7</b> Discharge Rates 50 Series Dryer . . . . .	16
<b>Figure 8</b> LAL Indicator . . . . .	22
<b>Figure 9</b> Discharge Drive Variator (Exploded View) . . . . .	32
<b>Figure 10</b> Discharge Variator Handwheel Control (Exploded View) . . . . .	34
<b>Figure 11</b> Discharge Variator Servo Motor (Exploded View) . . . . .	36
<b>Figure 12</b> Discharge Variator Servo Motor (Exploded View) . . . . .	38
<b>Figure 13</b> Discharge Reduction Gearbox (Exploded View) . . . . .	40

# Operating and Maintenance Instructions

---

## 1. INTRODUCTION

### a. Type 20,25,40 & 50 Grain Dryers

The range of KENTRA Continuous Flow Grain Dryers are based on the Mixed Flow Principle, where the Grain passes vertically through the Drying Column over alternate layers of Inlet and Exhaust Ducts. This design allows much higher Drying Air Temperatures to be used than in "Cross Flow Dryers" with consequently greater efficiency.

### b. Reserve Holding Section

Wet grain enters the Holding Section at the top of the Dryer, the main purpose of which is to maintain an effective air seal above the Drying Column. As standard the Reserve Section is fitted with a Proximity Switch to sense the level of grain in the Holding Section. If the level of grain falls below this switch, due to say a break in feed, then the Dryer will automatically shut down. In circumstances that prevent the Dryer being "flood-fed" (i.e. with a permanent grain overflow) arrangement can be made for the Dryer to control the grain feed equipment, by calling for feed "on-demand". This arrangement calls for the fitting of two additional proximity switches in the Dryer Holding Section above the level of the "empty probe". When the bottom probe of this pair is uncovered a signal is sent from the Dryer Control Panel calling for the Dryer Feed Equipment to start which then continues to run until the top probe is covered.

### c. Drying Column

From the Holding Section the grain passes into the Drying Column where the heated air from the Furnace evaporates the water present in the grain. As the grain passes through the Drying Sections its temperature gradually increases, however, due to the Mixed Flow principle as previously described the grain does not reach the temperature of the Drying Air.

### d. Furnace Unit

The Drying Air is heated by a three stage Oil Burner in a Direct-Fired Furnace, which is fitted with a special Air to Air Heat Exchanger. This type of arrangement is unique to Kentra Grain Systems Limited and ensures even temperature distribution in the Inlet Air Plenum together with the widest possible operating temperature range without the need for constant nozzle changing as is more usually the case with the more conventional two stage Oil Burner.

### e. Cooling Section

After passing through the Drying Column the Grain then enters the bottom cooling sections of the Dryer where Ambient air is used to cool the grain before it is discharged into the Discharge Hopper. As the Grain is cooled using Ambient air it is obvious that the discharged grain temperature will always be a few degrees above the ambient air temperature. It is for this reason that we always recommend that some form of low volume ventilation is available in the grain store to ensure that the grain can be cooled to a safe temperature necessary for long term storage.

## Operating and Maintenance Instructions

---

f. Discharge Unit

After passing through the Cooling Section the grain then passes through the Discharge Unit which is used to control the rate of grain throughput through the Dryer and hence the water evaporation rate. The discharge unit in the KENTRA Dryer is innovative in that it is a twin-roller unit having twice the number of rollers normally used by other Manufacturers. This ensures an even flow of grain through the drying column significantly reducing any risk of blockages. In operation the Rollers, which are mounted above the Discharge Trays, slowly rotate, turning the grain off the Discharge Trays into the Bottom Discharge Hopper. Adjustment of the speed of the Rollers, and hence the rate of throughput, is by means of a Variable Speed Drive Unit.

g. Dryer Control Panel (See **Figure 1**, Page 3)

The Dryer Control Panel contains all the necessary components and is wired to ensure safe and efficient operation of the Dryer. All controls and indicator lamps are clearly labelled for ease of recognition and use.

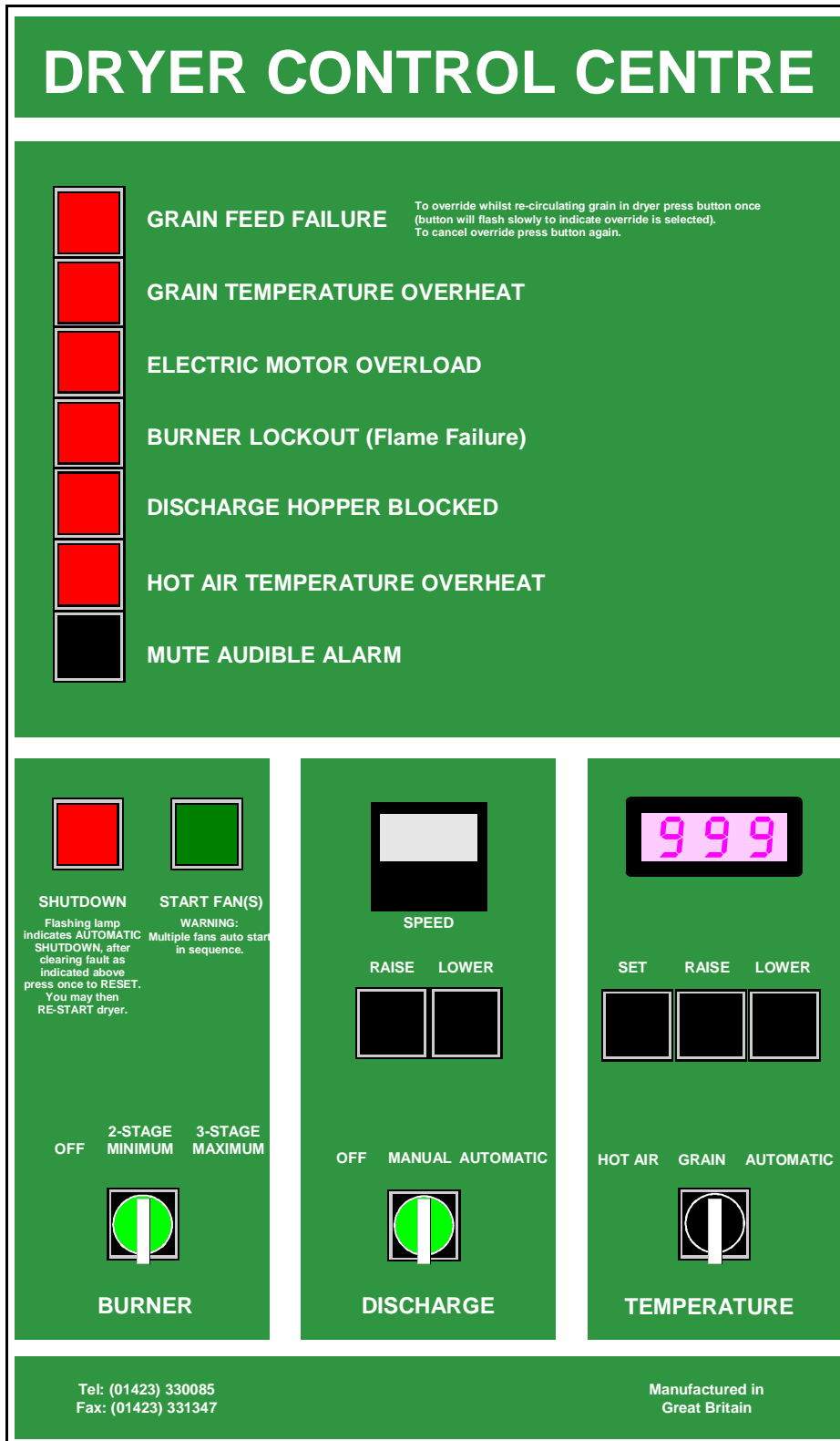

**Figure 1** Dryer Control Panel Layout

# Operating and Maintenance Instructions

---

## i. SYSTEM MONITOR

This section of the Control Panel comprises of five red indicator lamps, one red indicator pushbutton and one black pushbutton mounted vertically. Illumination of any of the six red lamps immediately causes the Dryer to shut down and activate the Alarm.

- (1) GRAIN FEED FAILURE is illuminated when the level of grain falls below the Reserve Empty Proximity switch in the Dryer Holding Section. Pressing the illuminated pushbutton overrides the proximity switch allowing the probe to become uncovered without causing the dryer to auto shutdown. This facility must ONLY be used during recirculation.
- (2) GRAIN TEMPERATURE OVERHEAT is illuminated when the Grain Temperature in the Drying Column exceeds the level set on the Control Panel.
- (3) HOT AIR TEMPERATURE OVERHEAT illuminates when the air temperature in the Inlet Air Plenum exceeds that set on the Control Panel by 10° Celsius.
- (4) BURNER LOCKOUT (Flame Failure) illuminates when a fault occurs on the Oil Burner. Reference to the lock out indicator on the LAL 2.25 Controller in the Control Panel and the chart in the Fault Finding Section of this Manual (see para. 5.c., page 22) will enable you to find the cause of the fault.
- (5) DISCHARGE HOPPER BLOCKED illuminates when grain builds up in the hopper below the Discharge Unit and covers the Proximity switch, as could be caused by a failure of the Dryer discharge conveyor, for example.
- (6) ELECTRIC MOTOR OVERLOAD indicates that one of the dryer electric motors has caused its thermal overload in the control panel to trip. Each of the overloads in the panel is fitted with a small indicator to show when it has tripped and can be reset by pressing the reset button fitted to the front of the overload unit.
- (7) MUTE AUDIBLE ALARM is used to silence the alarm sounder. This button MUST be pressed before pressing the SHUTDOWN button to clear the fault.

## ii. TEMPERATURE CONTROL

To adjust the temperature set values press the SET pushbutton below the digital display. The display will now show the set value for the currently selected mode. To display the values for the other modes turn the selector switch. Whilst holding down the SET pushbutton you can alter the set value by pressing either the raise or lower pushbuttons. The set values are retained in memory even after the mains power is switched off.

# Operating and Maintenance Instructions

---

## iii. TEMPERATURE MONITOR

A three digit LED display shows the actual operating values of the three temperature controllers. The rotary selector switch below the display is used to select which value is required.

## iv. DISCHARGE SPEED CONTROL (DMC30™ models only)

On dryers fitted with the DMC30™ Automatic Discharge Control the speed of the discharge drive motor, and hence the discharge rate of the dryer, is controlled from the dryer control panel. Pressing the RAISE or LOWER pushbuttons will raise or lower the speed of the discharge rate of the dryer. These pushbuttons are only effective when the discharge drive motor is running. Reference to the capacity charts starting on page 12 will give an approximation of the output rate of the dryer.

## v. BURNER CONTROL

A rotary selector switch enables the Operator to select whether to have the Burner OFF, on MINIMUM capacity or on MAXIMUM capacity. This switch can be operated at will though obviously if MAXIMUM capacity is selected for low temperature operation the burner will overshoot and the Dryer will shutdown.

## h. Maximum Air and Grain Temperatures

For the safe and economical operation of your KENTRA Grain Dryer it is essential that you thoroughly read and understand this section.

The grain and air temperatures in the accompanying table (**Table I**, Page: 7) refer to the moisture extraction rate shown; if the moisture extraction rate is GREATER than that shown the values in the table must be reduced, similarly if the moisture extraction rate is LESS than that shown the values in the table may be increased but care must be taken particularly if the crop being dried is required for seed or malting.

Where germination is important it is your responsibility to have the germinative capacity of the crop checked both BEFORE and AFTER drying.

As a general rule of thumb for every percentage point increase in the moisture extraction rate above that shown in the table reduce the drying air temperature by 2° Celsius.

# Operating and Maintenance Instructions

**Table I - Maximum Air & Grain Temperatures**

Crop Type	Moisture Extraction Rate	Maximum Drying Air Temperature	Maximum Grain Temperature
Feed Barley	20 - 15%	125° Cel	62° Cel
Feed Wheat			
Milling Wheat	20 - 15%	85 °Cel	48 °Cel
Malting Barley	24 - 15%	60 °Cel	44 °Cel
Malting Barley	20 - 15%	70 °Cel	44 °Cel
Malting Barley	18 - 12%	70 °Cel	44 °Cel
Seed Grains	20 - 15%	70 °Cel	44 °Cel
Oil Seed Rape	21 - 16%	85 °Cel	48 °Cel
†Oil Seed Rape	16 - 8%	85 - 90°Cel	50 °Cel
‡Oats for Human Consumption	15 - 10%	70 °Cel	45 °Cel
Peas/Beans	20 - 15%	85 °Cel	50 °Cel

† If the input m.c. exceeds 18% MCwb the rape must either be dried in two passes or batch dried. Do NOT dry continuously.

‡ If the maximum grain temperature is exceeded (regardless of input m.c.) the oats should either be batch dried or dried in several passes.

## 2. PRE-COMMISSIONING CHECKS

Before using your KENTRA Dryer for the first time it is essential that you have the following checks carried out to ensure that your new Dryer is ready to be put into operation. Certain of these checks must only be carried out by qualified personnel (e.g. Electrical Checks) and are marked as such where necessary.

- a. Electrical Inspection (Before Mains Power is Applied)

The following checks are to be performed only by suitably qualified personnel.

- i. The Control Panel should be firmly fixed to a secure wall and should be connected to a suitably sized and protected Mains Supply.

## Operating and Maintenance Instructions

---

- ii. All Electrical Connections on both the Dryer and the Control Panel Terminal Rail should be thoroughly checked for good connection and tightness.
  - iii. All Cables from the Dryer Control Panel should be checked for continuity. Take care when doing this as there are sensitive electronic devices within the Control Panel. If you are in any doubt contact Kentra Grain Systems Limited.
  - iv. Ensure that all Earth Connections are tight and if any RCCBs or ELCBs are fitted make sure that they function correctly.
  - v. Check and set the Overload Relays within the Control Panel, check the individual Motor Serial Plates for the correct FLC Values.
  - vi. Thoroughly clean the inside of the Control Panel paying particular attention to loose strands of cable and drilling swarf which may contaminate the Relay Contacts causing failure. Such damage is not covered under Warranty!!!
- b. Electrical Inspection (After Mains Power is Applied)
- The following checks are to be performed only by suitably qualified personnel.
- i. Check for correct operation of all Temperature Controllers and Indicators.
  - ii. Check that all Proximity Switches function correctly.
  - iii. Check all Electric Motors for correct rotation and adjust where necessary.
  - iv. Check that each Electric Motor's running current does not exceed the FLC shown on the Motor Rating Plate.
- c. Fuel Supply Inspection
- i. The Fuel Tank should be positioned so that the tank outlet is level with or above the level of the Oil Burner Fuel Pump. If this is not the case contact Kentra Grain Systems Limited for advise.
  - ii. The Supply Line from the Tank to the Oil Burner must be installed with proper levels for a gravity system without air pockets.
  - iii. The Supply Line must be free of fuel leaks and there must be no air leaks.
  - iv. Any additional filters or strainers fitted to the fuel supply line must not impede the fuel flow.
  - v. Termination of the oil supply pipe(s) must allow tension free connection of the flexible oil hoses. Both oil and electrical connections must allow the burner to swing open.
  - vi. The oil filter supplied must be installed to protect the burner fuel pump and system, and should be mounted at the termination of the oil supply to the burner.

# Operating and Maintenance Instructions

The following faults can occur if a filter is not fitted.

M Seizing of the pump drive

M Blocking of solenoid valves and nozzles

**YOU HAVE BEEN WARNED!!!**

- vii. The flexible hoses supplied with the burner are of a high quality and covered with a woven wire sleeve cover. Properly installed they will give years of trouble free service. When installing care must be taken to ensure that the hose is not twisted. In order to guarantee strain free installation the hose should first be loosely fixed at one end, then moved through the required hose movement 2 to 3 times, so that the hose can align without distortion, and then tighten in position.

A second spanner must be used to counter hold when tightening. Particular care should be taken that the hoses do not foul each other or other equipment during operation. The hose connections can be installed for either burner hinge direction as required.

## d. Discharge Unit Inspection

- i. The discharge unit must be checked to ensure that there is no debris in the unit. (nuts, bolts, etc. left over from the installation)

- ii. The rollers must be checked for correct direction of rotation. This

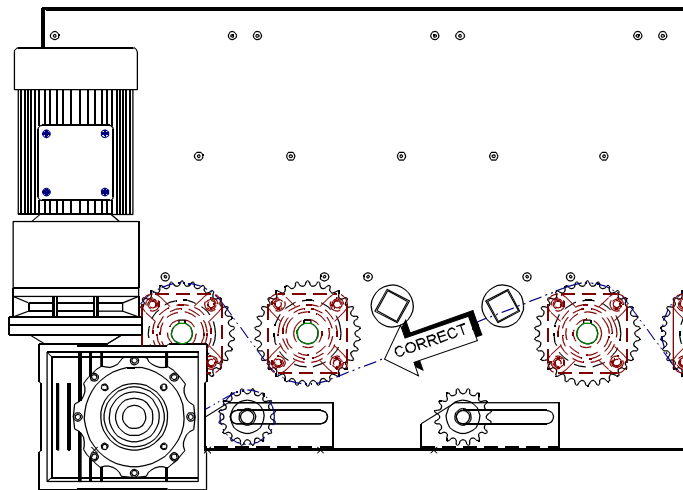

**Figure 2** Chain Drive Rotation Direction

is most important as serious damage could result if the rollers are allowed to rotate in the wrong direction. (See **Figure 2**)

- iii. The chain drive must be checked for correct tension and lubricated, and the variable speed drive unit must be operated throughout its entire speed range.
- iv. The discharge trays must be checked for free movement using the wrench provided. The gas springs require quite a large effort to move them but there

## Operating and Maintenance Instructions

---

should be no tight spots through the full travel of the tray lever.

- e. Dryer Inspection
  - i. Check that, where necessary, all access doors are securely fastened.
  - ii. Check that all air control slides are free to operate and adjust where necessary.
  - iii. If the Dryer is erected outside make sure that all the holding down bolts are secure and properly tightened.
  - iv. Finally check thoroughly around the Dryer to make sure that all bolts are tight and that all erection debris, such as nuts, bolts, etc., have been cleared up.

# Operating and Maintenance Instructions

---

**Table II - Dryer Standard Capacity**

---

The dryer capacity chart can be used to estimate the performance of any Kentra dryer, expressed as a percentage factor against standard performance at 125° Celsius (factor of 100%). Please note that capacities are based on standard cooling with no account made of changes in the ratio of drying to cooling zones. For capacities drying to moisture contents other than 15% MCwb please contact our office for further advice.

Dryer Model	Rated Throughput (tonnes per hour)	Dryer Model	Rated Throughput (tonnes per hour)
720	6.3	825	8.0
920	8.3	1125	10.5
1120	10.4	1325	13.0
1320	12.5	1625	16.0
		1925	18.5
		2225	21.5
1340	12.6	1650	16.0
1740	16.6	2150	21.0
2140	20.8	2650	26.0
2540	25.0	3250	32.0
3040	29.2	3750	37.0
3440	33.4		

---

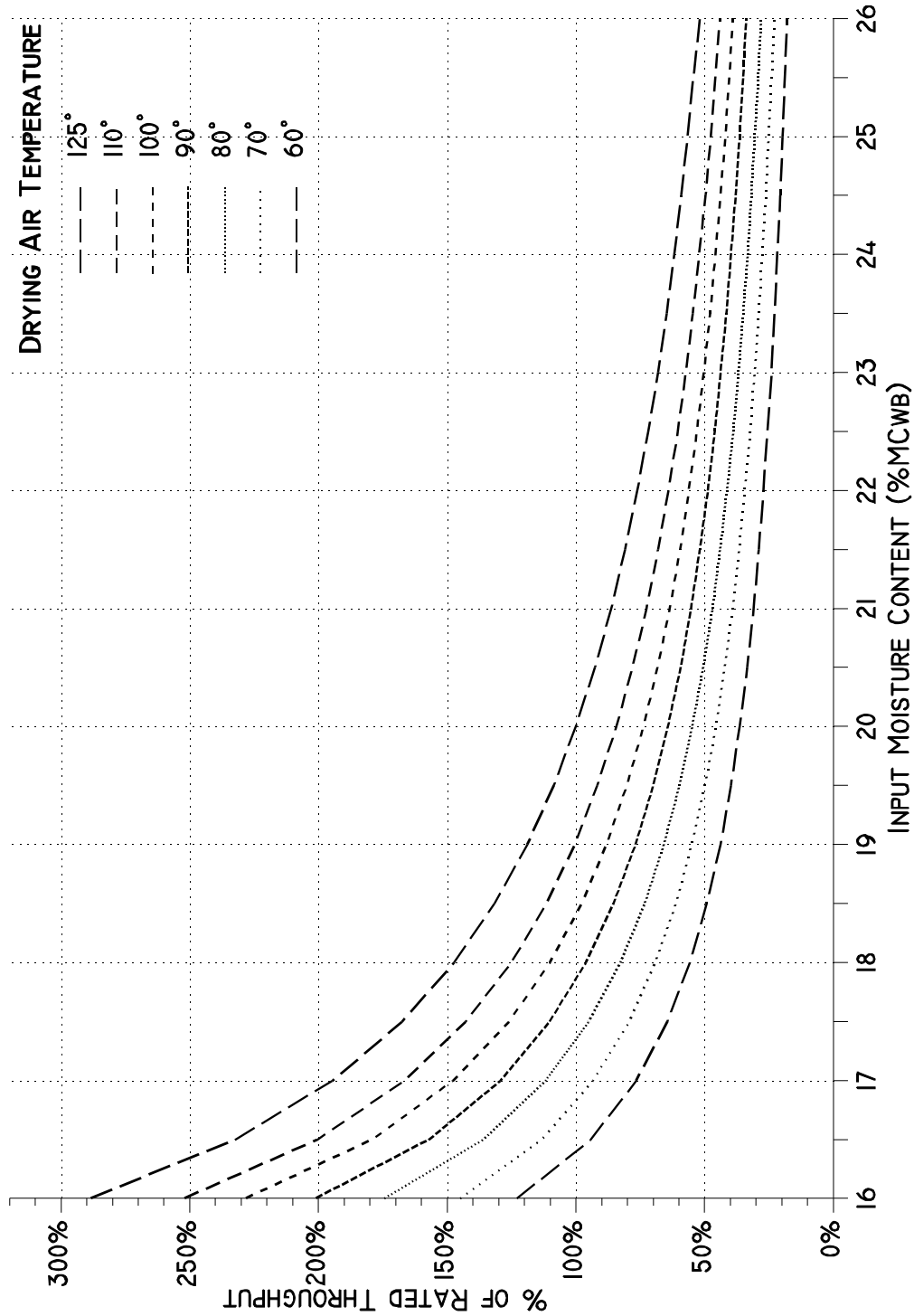

Figure 3 Dryer Capacity Curve

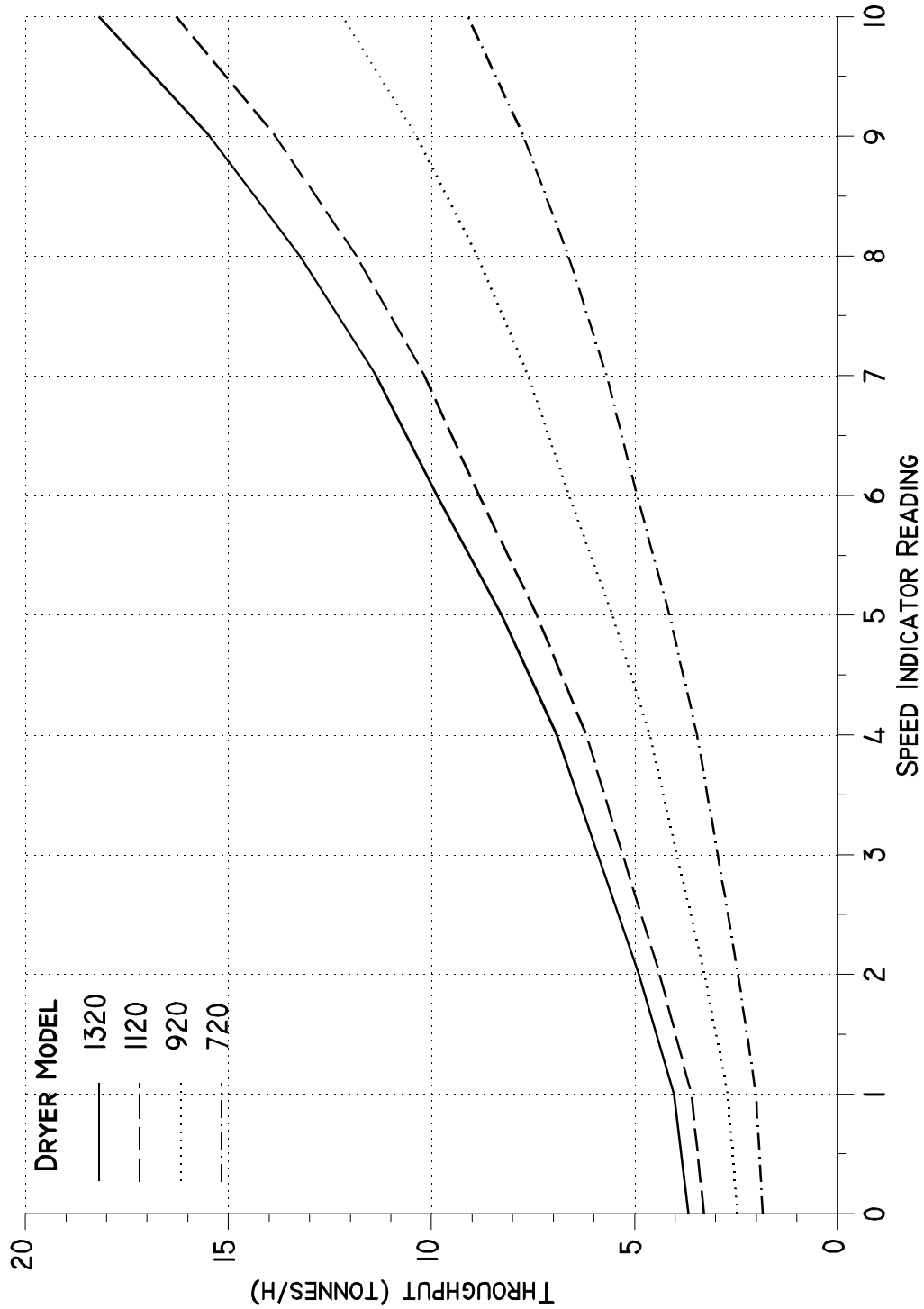

Figure 4 Discharge Rates 20 Series Dryer

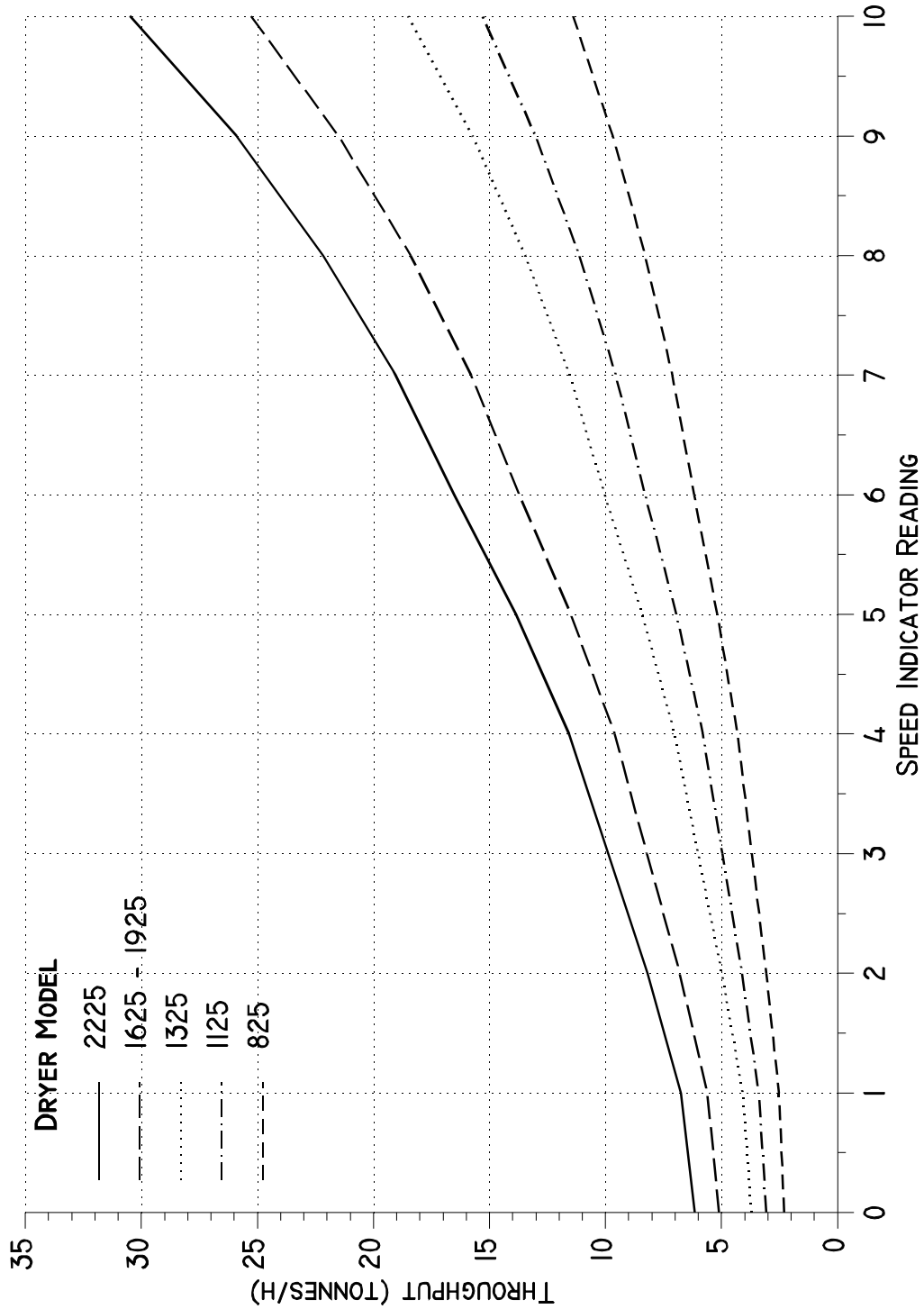
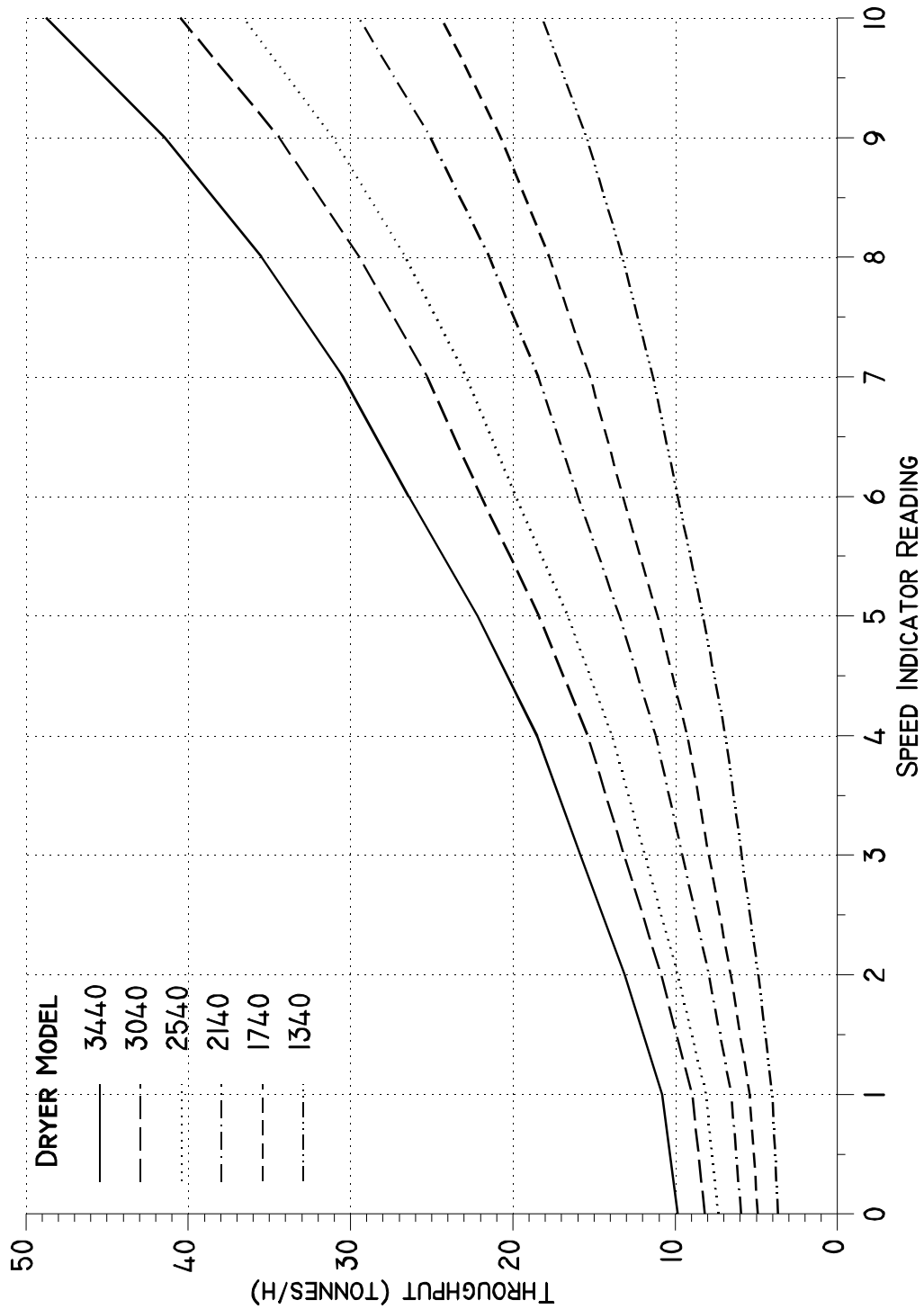
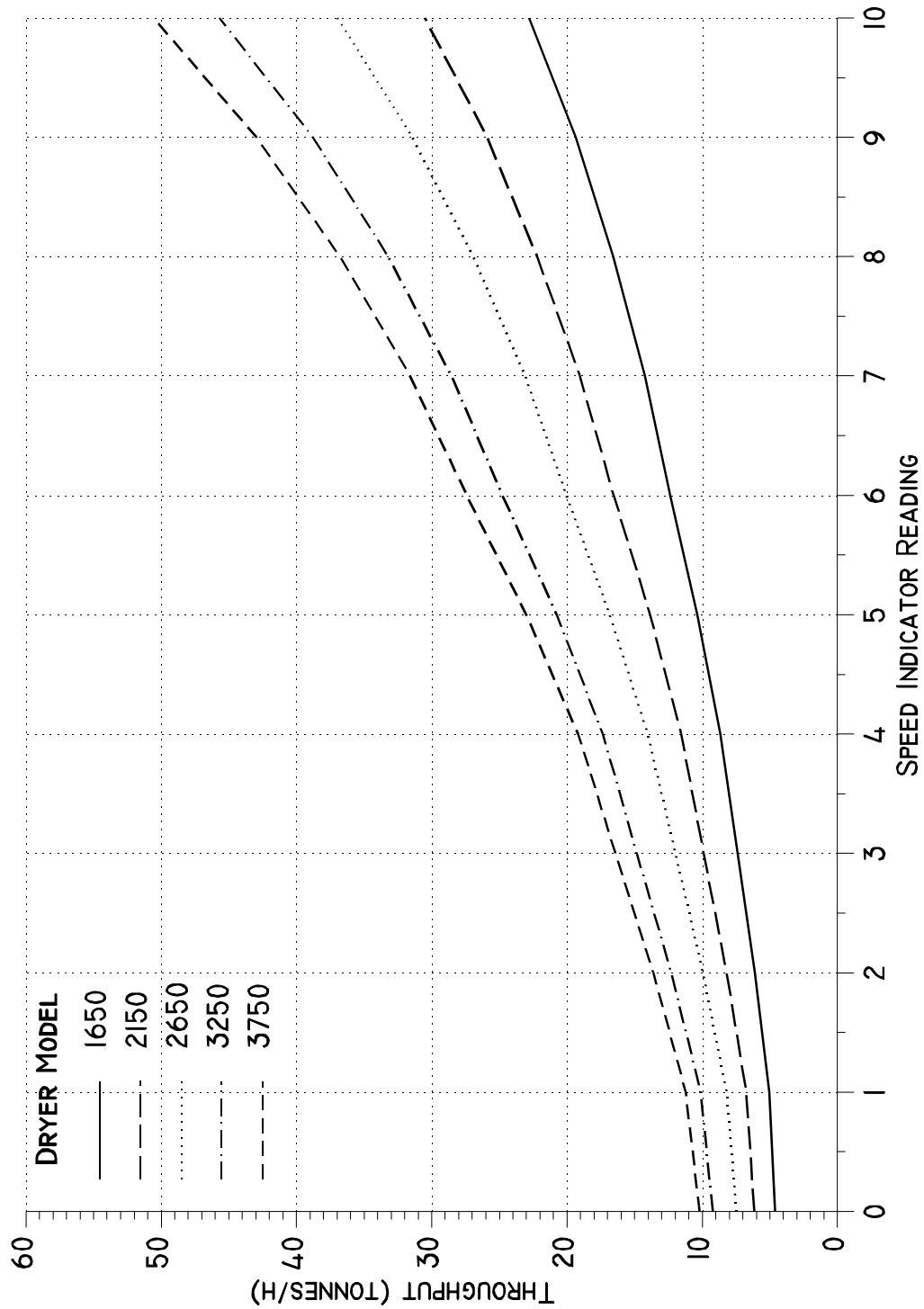

Figure 5 Discharge Rates 25 Series Dryer



**Figure 6** Discharge Rates 40 Series Dryer



**Figure 7** Discharge Rates 50 Series Dryer

# Operating and Maintenance Instructions

---

## 3. DRYER OPERATION

Before filling the Dryer with grain, check that all the cleanout doors and access hatches are shut, and that the discharge trays are in the working position. When you are happy that the Dryer is ready to run switch on the Control Panel Mains Isolator and press the 'Emergency Stop' RESET button. The Control Panel will then follow a preset self test which includes a lamp and audible alarm test. When the audible alarm test has completed (5 second delay) simply press the SHUTDOWN DRYER push-button to switch the system into standard running mode.

### a. Filling the Dryer

Fill the Dryer with wet grain. If the Dryer is equipped for "Feed-on-Demand" it is necessary to have the Dryer Control Panel switched on before starting the external feed equipment, when the dryer is full the external feed conveyor controlled by the dryer will then stop automatically.

### b. Starting with Wet Grain

After filling the Dryer with grain, set the TEMPERATURE CONTROLS to the desired values (for guidance refer to Section 1.h., page 5). Press the START FANS push-button and switch on the burner. The Dryer Fan(s) will automatically start in sequence followed a short while later by the Burner which will build up the Drying Air temperature to the set value and then automatically regulate itself to maintain the set value. While the dryer is warming up estimate the dryer throughput using the Dryer Capacity Chart (See Page 12). After approximately 15 minutes start the dryer discharge by selecting MANUAL. Please note that if the discharge switch is already in either MANUAL or AUTOMATIC before starting the fans the discharge unit will automatically start. (MAKE SURE ALL THE NECESSARY CONVEYORS ARE RUNNING!!)

The Wet Grain in the Cooling Section of the Dryer should now be recirculated back to the top of the Dryer until the output moisture content of the grain is within 2% of the target value.

If, due to the plant design, it is not possible to recirculate the grain the following procedure should be adopted:

After pre-heating the grain in the drying column select MANUAL discharge to start Continuous Drying, ensuring that there is an adequate feed of grain to the Dryer to prevent it from running empty. However, as the grain that is initially discharged from the Dryer is still wet it should either be diverted to a trailer or to a convenient place in the store where it can be easily returned to the Intake Pit for processing later. Again, when the output moisture content is within 2% of the target value the discharged grain should be diverted to the Store.

Once grain is being sent to the store and MANUAL mode has been selected regular checks should be maintained every 30 minutes on the grain output moisture content. If the grain remains WETTER than desired the discharge speed should be slightly REDUCED, or if the grain remains DRYER than desired the discharge speed should be slightly INCREASED.

# Operating and Maintenance Instructions

---

During the initial period after re-circulation it is not uncommon for the grain temperature to vary erratically for no apparent reason. This is due to partially dried grain passing through the grain column for a second time and should quickly settle down once fresh wet grain from the Intake enters the Dryer.

After approximately 2 hours the Dryer should have stabilised sufficiently to allow AUTOMATIC operation, which is described in more detail later in this section.

c. Re-starting a Full Dryer

When re-starting a Dryer full of grain from a previous drying session, first ensure that the Reserve Holding section is full of grain. It is not necessary to recirculate as the cooling sections of the Dryer are full of dried grain. However it is still necessary to pre-heat the Dryer for approximately 5 - 10 minutes before starting to discharge grain.

If the Dryer has been run previously on AUTOMATIC it can be selected immediately, provided the previous settings have been retained.

d. Dryer Shutdown

To finish a drying session it is only necessary to press the SHUTDOWN push-button. This immediately stops the Discharge and switches off the Oil Burner, the Dryer Fans continue to run, however, for 30 minutes. This is essential to both cool the grain in the drying column and to prevent condensation occurring in the drying column. An alternative method of stopping the Dryer is to cut off the grain feed. The Dryer will continue to run, of course, until the GRAIN FEED FAILURE Proximity Switch is uncovered whereupon an alarm will be activated causing the Dryer to automatically go into shutdown. This has an added advantage in that it clears all the Dryer feed equipment of grain.

## 4. AUTO-DISCHARGE CONTROL

a. Description

The purpose of the Auto-Discharge controller is to maintain a constant grain output moisture content irrespective of the input grain moisture content. It is however only possible to maintain any level of accuracy ( $\pm 1\%$ ) within a finite range of input moisture content. (typically  $\pm 5\%$ )

It is now a known fact that for a constant drying air temperature with a constant moisture extraction rate the Dryer exhaust temperature also remains constant. If the input moisture content INCREASES the exhaust temperature will DECREASE and similarly if the input moisture content DECREASES the exhaust temperature will INCREASE. By monitoring these changes in temperature it is possible to control the grain output moisture content by varying the rate of throughput of the Dryer.

To control the throughput rate of the Dryer the controller is allowed to stop the discharge drive, however to prevent the possibility of grain over-heating this stop period is limited to a maximum time of 2 minutes.

b. Auto-Discharge Control Set-Up Procedure

# Operating and Maintenance Instructions

---

## **IMPORTANT**

After making any adjustment always wait for at least 30-45 minutes (dependent on moisture extraction rate) and note what effect that adjustment has before making any further adjustments, and NEVER make large changes.

For example a Dryer rated at 20 tonnes per hour will have a holding capacity of approximately 25 tonnes and under normal conditions (drying from 20% - 15% at 125°Cel.) will have a residence time of 1¼ hours. However, the MINIMUM throughput capacity of the machine will be of the order of 5 tonnes per hour. You can see that at minimum speed the residence time is approximately 5 hours. To reduce speed from normal rated throughput (20 tonnes per hour) to minimum (5 tonnes per hour) would mean that the effect of that adjustment would not be seen for at least 3 to 4 hours!!! Unfortunately by then the damage is done as the drying column will contain at least 20 tonnes of excessively over dried grain and to recover from that misadjustment will take at least a further 3 - 4 hours. The nett result, of course, is the LOSS OF A FULL DAYS DRYING.

To be successful in operating the Dryer on Automatic Control it is essential that the drying process is stabilised before attempting to switch to automatic, under normal circumstances this takes about 2 hours.

After stabilising the Dryer the discharge rate is INCREASED one division on the indicator by pressing the DISCHARGE SPEED RAISE pushbutton<sup>1</sup>. It is necessary to increase the discharge rate to ensure that the Automatic Discharge Control can react successfully to reductions in Input Moisture Content.

The Auto-Discharge Control is then set to the indicated temperature for AUTOMATIC on the Temperature Monitor and then finally AUTOMATIC is selected on the DISCHARGE switch.

c. Automatic Discharge Control Fault Finding

If the Automatic Discharge Controller is incorrectly set the output grain moisture content will either be higher or lower than required.

If the grain output moisture content is lower than required and the discharge drive is running constantly then the discharge speed needs INCREASING.

If the grain output moisture content is higher than required and the discharge drive is constantly stopping then the discharge speed needs REDUCING.

If the grain output moisture content is consistently either below or above the required moisture content, but the Automatic discharge Control appears to be functioning correctly, then the Auto Discharge Temperature Controller requires slight adjustment. If the grain

---

<sup>1</sup> Operators of dryers fitted with the DMC20 Auto Discharge Control will have to adjust the discharge rate by turning the indicator handwheel fitted to the discharge drive unit.

---

# Operating and Maintenance Instructions

---

output moisture content is lower than required then REDUCE the setting by one degree. If the grain output moisture content is higher than required then INCREASE the setting by one degree.

## 5. FAULT FINDING

### a. Fault Protection and Shutdown Procedure

To ensure safety and efficiency the Dryer Control Panel constantly monitors the Dryer whilst it is in operation. If any fault occurs whilst the Dryer is in operation a red lamp will illuminate on the Dryer Control Panel indicating the nature of the fault. At the same time the Dryer Control Panel will activate the Shutdown Procedure immediately switching off the Oil Burner and Dryer Discharge and activating the Fan Shutdown Timer which allows the Fan(s) to run for a further 30 - 40 minutes. An external Alarm Sounder (if fitted) will also activate which can be cancelled by pressing the MUTE AUDIBLE ALARM push-button on the Control Panel. Indication of the cause of the fault remains until the fault has been rectified and the SHUTDOWN push-button has been pressed.

Providing the fault has been rectified (e.g. Grain Feed re-established after a GRAIN FEED FAILURE Alarm) the Dryer can be restarted by pressing the SHUTDOWN push-button before the end of the 30 minute shutdown time, and then pressing the START FAN(S) push-button.

### b. Electrical Fault Finding Procedure

Should a fault occur in the Dryer Control Panel all fuses and circuit breakers should first be checked for correct function, and all electrical connections should be checked to ensure good contact. In general, most Dryer Electrical faults occur because of an external wiring fault, (wires eaten by mice, etc) and so annual electrical checks become essential both for uninterrupted operation during harvest and safety. (fire risk!!)

If basic checks do not solve the problem, reference to the circuit diagram supplied with the Dryer should enable any competent Electrician to rectify the fault. Should the fault appear to be in the PLC Controller and you are at all unsure what to do, please do not hesitate to contact us either directly or through your Dealer for advice.

# Operating and Maintenance Instructions

## c. Burner Lockout

Reference to the lock out indicator on the LAL 2.25 and the accompanying table will enable you to isolate the cause of the burner lock out.

◀ No start e.g. because the closed signal has not been supplied to terminal 8 by the limit switch on the burner servomotor or because a contact has not been closed between terminals 12 and 4 or 4 and 5 of the LAL 2.25.

▲ Controlled shut down because the open signal has not been supplied to terminal 8 of the LAL 2.25 by the limit switch on the burner servomotor.

○ Lockout due to a fault in the flame supervision circuit.

▼ Controlled shutdown because the position signal for the low flame position has not been supplied to terminal 8 by the auxiliary switch on the burner servomotor.

1 Lockout because no flame signal has been received on completion of the 1st safety time. Any flame signal failure after completion of the 1st safety time also causes the control to go to lockout.

\* Lockout because the flame signal has been lost during burner operation.

◀ Lockout on completion of control programme sequence due to extraneous light or fault in the flame supervision circuit.

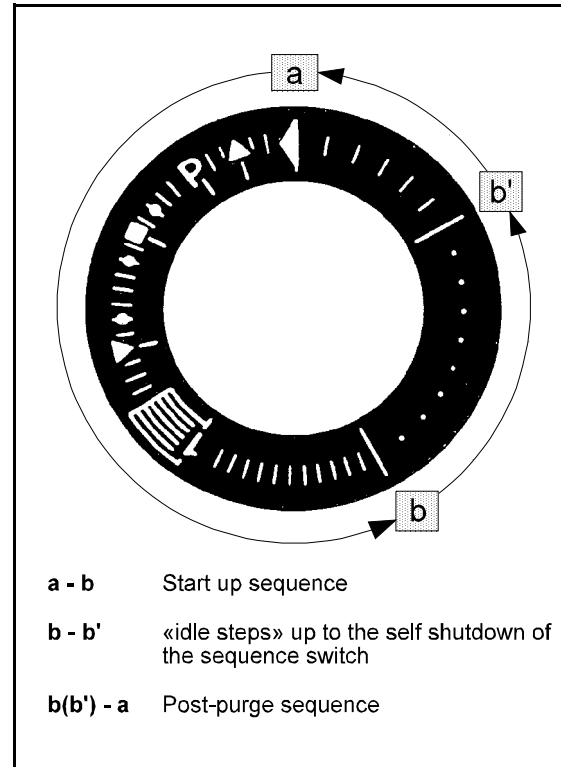

**Figure 8** LAL Indicator

If lockout occurs at any other point between start and pre-ignition, which is not marked by a symbol there is normally a premature i.e. faulty flame signal.

## Operating and Maintenance Instructions

### d. Fault Finding Chart

FAULT	POSSIBLE CAUSE	REMEDY
Hot Air Temperature Overheat Warning	This may occur when the Dryer is started from cold.  Faulty Burner Servo Motor.	Carry out fault reset procedure.  Call Service Engineer.
Grain Temperature Overheat Warning	Hot Grain Temperature set value is too low.  Grain Temperature Setting Correct but drying air temperature set too high for product being dried.	Set to correct value and carry out fault reset procedure.  Reset air temperature to correct value and carry out fault reset procedure.
Empty Alarm during drying, burner and discharge stop.	Wet grain supply interrupted.	Restore wet grain supply and carry out fault reset procedure.
Discharge Blockage Alarm during drying.	Dry grain build up in discharge hopper.	Clear discharge hopper outlet and rectify cause of blockage. Carry out fault reset procedure
Burner will not start, no LOCKOUT warning	Burner not firmly secured by locknut.	Tighten locknut.
Burner will not start, LOCKOUT warning	Burner motor circuit breaker tripped.  Fuel filter blocked or no fuel supply.  No spark at electrodes, due to wear or maladjustment.	Reset trip and investigate cause.  Remove and clean dirty components, and/or restore fuel supply. Carry out fault reset procedure  Replace if necessary and re-adjust. Carry out fault reset procedure
Burner ignites but flame goes out after ≈15 seconds, LOCKOUT warning	Photocell dirty.	Clean or replace photocell. Carry out fault reset procedure

## Operating and Maintenance Instructions

FAULT	POSSIBLE CAUSE	REMEDY
<p>Flame ignites but is very orange in colour, possible black smoke.</p>	<p>Too little combustion air.</p> <p>Worn nozzle.</p> <p>Build up of dust on flame diffuser.</p> <p>Badly adjusted diffuser.</p> <p>Incorrect oil pressure.</p>	<p>Check for loose or worn nozzles.</p> <p>Check servo motor cam switch settings. (see oil burner manual).</p> <p>Replace nozzle.</p> <p>Clean diffuser.</p> <p>Check and adjust.</p> <p>Check and adjust.</p>
<p>Flame ignites but is harsh and blue, fumes from fan exhaust sting eyes, possible white smoke.</p>	<p>Too much combustion air.</p> <p>Blocked nozzle</p> <p>Build up of dust on flame diffuser.</p> <p>Badly adjusted diffuser.</p> <p>Incorrect oil pressure.</p>	<p>Check for restrictions in fuel supply e.g. blocked oil filter.</p> <p>Check servo motor cam switch settings. (see oil burner manual).</p> <p>Clean nozzle</p> <p>Clean diffuser.</p> <p>Check and adjust.</p> <p>Check and adjust.</p>

## 6. HEALTH & SAFETY CONSIDERATIONS

### a. Noise Hazard

If the dryer is installed inside the grain store along with other grain handling equipment it will be necessary to check the total noise level of the plant to ensure that the operator is not subjected to an excessive noise level in the workplace. 'Action Levels' are values of 'daily personal exposure to noise', shortened to  $L_{EP,d}$ . These depend on the noise level in the working areas and how long people spend in them during the day. The first action level is an  $L_{EP,d}$  of 85 dB(A) and the second action level is an  $L_{EP,d}$  of 90 dB(A).

#### **Decide whether you might have a problem**

If people have to shout or have difficulty being understood by someone about two metres away, you might have a problem. To be sure about this you will need to get the noise assessed. Your local dealer should be able to help you with this, otherwise we can put you in touch with a noise consultant.

#### **Ear protection**

If people have to work in noise-hazardous areas they will need ear protectors (ear muffs or ear plugs). However, these should not be regarded as a substitute for noise reduction.

Between the first and second action levels you should make sure that:

- ! protection is freely available
- ! the workers know that unless they wear it there is some risk to their hearing.

### b. Electrical Hazard

All electrical equipment must be installed in accordance with the latest IEE regulations, currently 16th edition, BS7671 1992 incorporating Amendment No1 1994 (amd. 8536).

The dryer control panel incorporates a number of circuit protection devices such as circuit breakers and thermal overloads. These devices are for your protection and if they operate they do so for a reason! Always find out the reason why a safety device operates before resetting it and if in doubt ask us or your local qualified electrician for guidance.

Before working on any electrical components or circuits the dryer control panel MUST be isolated from the mains supply by switching off the door mounted isolator. Do not rely on emergency stop buttons, these only isolate the dryer control circuits, NOT the main 3 phase power circuits. If you wish you can padlock the isolator in the OFF position, this is recommended if it is your intention to work inside the dryer whilst carrying out routine maintenance, etc.

### c. Fire Hazard

The process of drying grain at high temperatures requires the input of extremely large amounts of energy. To reduce the risk of fire occurring within the dryer it is necessary to maintain the dryer in good mechanical condition and to keep the dryer clean. A build up

## Operating and Maintenance Instructions

---

of chaff and dust within the dryer plenums and drying column will ultimately lead to blockages creating 'dead areas' where grain flow is impaired. In these 'dead areas' the grain starts to overheat and overdry, any chaff becoming tinder dry. A stray spark from the dryer furnace will ignite this dry material very easily. In case of fire it is essential to stop the dryer fans and extinguish the burner as quickly as possible, this can be achieved by pressing the 'Emergency Stop' which is situated on the front of the dryer control panel (Your electrician may have fitted further Emergency Stops around the plant, please make sure you are aware of all their positions). Having stopped the dryer get it emptied as quickly as possible so that the emergency services, if required, can deal with the burning material easily, on the ground. However, **DO NOT TAKE ANY RISKS**, if you are at all unsure what to do, call the Fire Brigade.

## 7. LUBRICATION

### a. Discharge Drive Variator

All moving parts in the variator are metal, and being kinematic require constant lubrication, which is provided by splash/jet. Oil should show at the level plug centre with the variator at standstill; if this is not the case, top up with the type of oil specified. The oil should be changed after an initial running in period of 100 working hours and annually thereafter. During the initial running in period the temperature of the variator will be higher than normal and may rise up to 40/45°C above ambient. After 60 to 80 hours operation the variator should be run in and the temperature of the variator will stabilize at around 20°C above the ambient temperature.

**Table III** - Recommended Lubricants, Variator

---

<b><i>RECOMMENDED OILS</i></b>	
<i>IP</i>	<i>IP DEXRON FLUID</i>
<i>AGIP</i>	<i>A.T.F. DEXRON</i>
<i>BP</i>	<i>BP AUTRAN DX</i>
<i>CHEVRON</i>	<i>A.T.F. DEXRON</i>
<i>ESSO</i>	<i>A.T.F. DEXRON</i>
<i>FINA</i>	<i>A.T.F. DEXRON</i>
<i>MOBIL</i>	<i>A.T.F. 220</i>
<i>SHELL</i>	<i>A.T.F. DEXRON</i>

---

# Operating and Maintenance Instructions

---

## b. Worm Gear Unit

Gear unit size NMRV70 as fitted to Type 20 & 25 Dryers is supplied lubricated for life, packed with synthetic grease; accordingly, this unit has a filler and drain plug, but no level indicator plug. Gear unit size NMRV90 as fitted to Type 40 & 50 Dryers is supplied filled with mineral oil, and is provided with filler, drain and level plugs; care must be taken once the unit is installed that the breather plug fitted to this unit is kept clear.

**Table IV - Recommended Lubricants, Worm Gear Units**

---

<i>GEARBOX TYPE</i>	<i>QUANTITY</i>	<i>LUBRICANT Ambient Temperature (0÷30)*C</i>	<i>MANUFACTURER</i>
NMRV70	0.50kg	Telesia Compound B Tivela Compound A	IP SHELL
NMRV90	1.50ltr	Omala oil 320 Mellana oil 320 Mobilgear 632 Spartan EP	SHELL IP MOBIL ESSO

N.B.:

1. For ambient temperatures above 35°C, oil with a higher rated viscosity should be used.
  2. For ambient temperatures below 0°C, oil with a lower rated viscosity should be used.
  3. Synthetic greases for longlife lubrication can be used in ambient temperatures of -15°C to 40°C.
- 

## 8. PRE SEASON MAINTENANCE

To ensure trouble free service during the drying season the dryer should be fully serviced in good time beforehand by a competent engineer familiar with grain dryers and pressure jet oil burners.

- a. **THOROUGHLY** clean down the dryer, including the plenum chambers, the drying column and the furnace heat exchanger.
  - b. The oil burner should be thoroughly cleaned and the nozzle head, combustion tube and diffuser checked for carbon contamination and oil leaks. A build up of carbon would indicate that the burner was incorrectly set. Each nozzle should be removed and the nozzle filter should be cleaned. **DO NOT ATTEMPT TO CLEAN THE NOZZLE ORIFICE UNLESS YOU ARE ABSOLUTELY SURE OF THE CORRECT PROCEDURE.**
  - c. The burner electrodes should be cleaned and checked for correct adjustment.
  - d. Remove and clean the fuel filter and check for water contamination.
-

# Operating and Maintenance Instructions

---

- e. Remove, clean and check for correct operation of the QRB flame sensor.
- f. Lightly lubricate all burner linkages.
- g. Inspect all fuel lines for leaks and damage.
- h. Check all PT100 temperature sensors are clean, undamaged, in the correct positions and function correctly.
- i. Check all proximity switches are clean and functioning correctly.
- j. Check and lubricate the discharge drive chain.
- k. Check all drive sprockets for wear and/or misalignment. Rectify if necessary.
- l. LIGHTLY grease discharge roller bearing housings. (One stroke from a grease gun will be sufficient)
- m. Check that all the discharge trays can open fully and that all the gas springs are functioning correctly.
- n. Operate the discharge throughout its full speed range and ensure that minimum and maximum speed can be attained.
- o. Inspect all electrical cables for fraying, damage, loose connections, rat or mice damage and repair/replace as necessary.
- p. Clean the inside of the control panel and check for correct function of all overload relays, etc. Ensure all electrical connections are tight with no signs of contact corrosion.

## **9. POST SEASON MAINTENANCE**

- a. Remove all grain, straw and other residues from the bottom of the plenum chambers and the whole of the drying column. It may be necessary to use an industrial vacuum cleaner or even a high pressure hot water cleaner to properly remove any oil seed residues. (If high pressure water is used ensure all electrical connections are water tight and that mains power is OFF before starting)
- b. Check the inside of all the air ducts for build up of chaff and straw and remove if present using a long handled brush.
- c. Check the fans for damage and/or loose blades and clean.
- d. Thoroughly clean the dryer discharge unit and check the roller drive chain for correct tension and lubricate.
- e. Clean down the oil burner, check for fuel leaks and repair if required.
- f. Switch off the control panel, open the door and thoroughly clean out the interior of the panel removing all traces of dust, chaff, spiders webs, etc.

## Operating and Maintenance Instructions

---

- g. With all the hatches open run the dryer fan(s) until the dryer has been thoroughly ventilated and dried out. If you wish to run the oil burner do not set the air temperature higher than 50° Cel.
- h. Keep the dryer well ventilated when it is not in use and DO NOT use the drying column as a storage silo.

Regular maintenance saves energy and  
protects the environment

# Operating and Maintenance Instructions

---

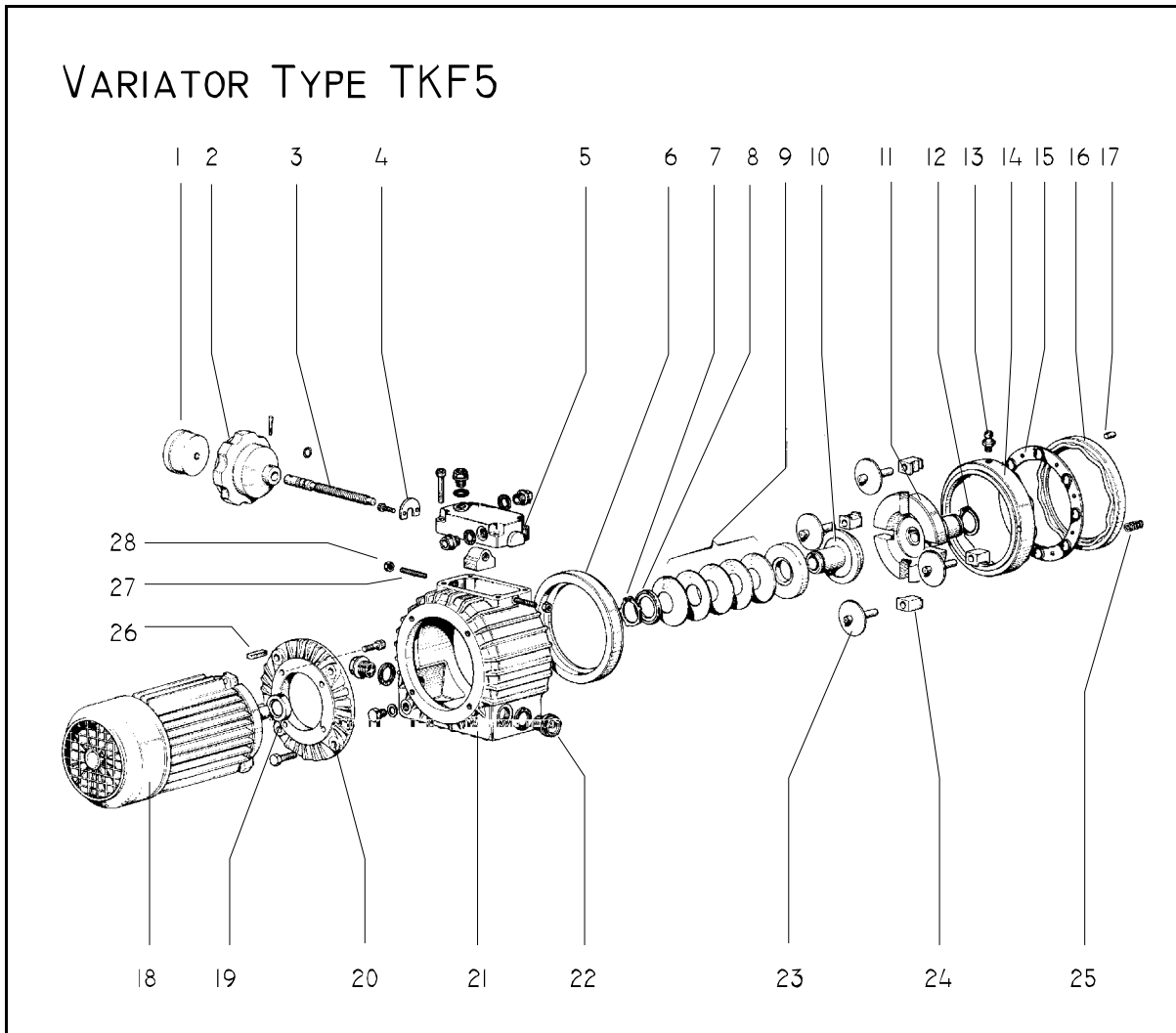

**Figure 9** Discharge Drive Variator (Exploded View)

# Operating and Maintenance Instructions

---

**Table V - Key to Figure 9**

---

Item	Description	Item	Description
1	Indicator	15	Ball Ring
2	Handwheel	16	Cam Ring
3	Control Screw	17	Grub Screw
4	Stop Washer - Control Screw	18	Electric Motor
5	Cover - Control Screw	19	Oil Seal - Motor Shaft
6	Fixed Annulus Race	20	Motor Mounting Flange
7	Circlip	21	Variator Casing
8	Stop Ring - Belville Springs	22	Oil Level Plug
9	Belville Spring Assembly	23	Planet Disk
10	Fixed Sun Race	24	Friction Bearing - Planet Disk
11	Planet Carrier	25	Coil Spring
12	Circlip	26	Parallel Key
13	Annulus Control Ball	27	Stud Screw - Limit Stop
14	Adjustable Annulus Race	28	Nut - Limit Stop

---

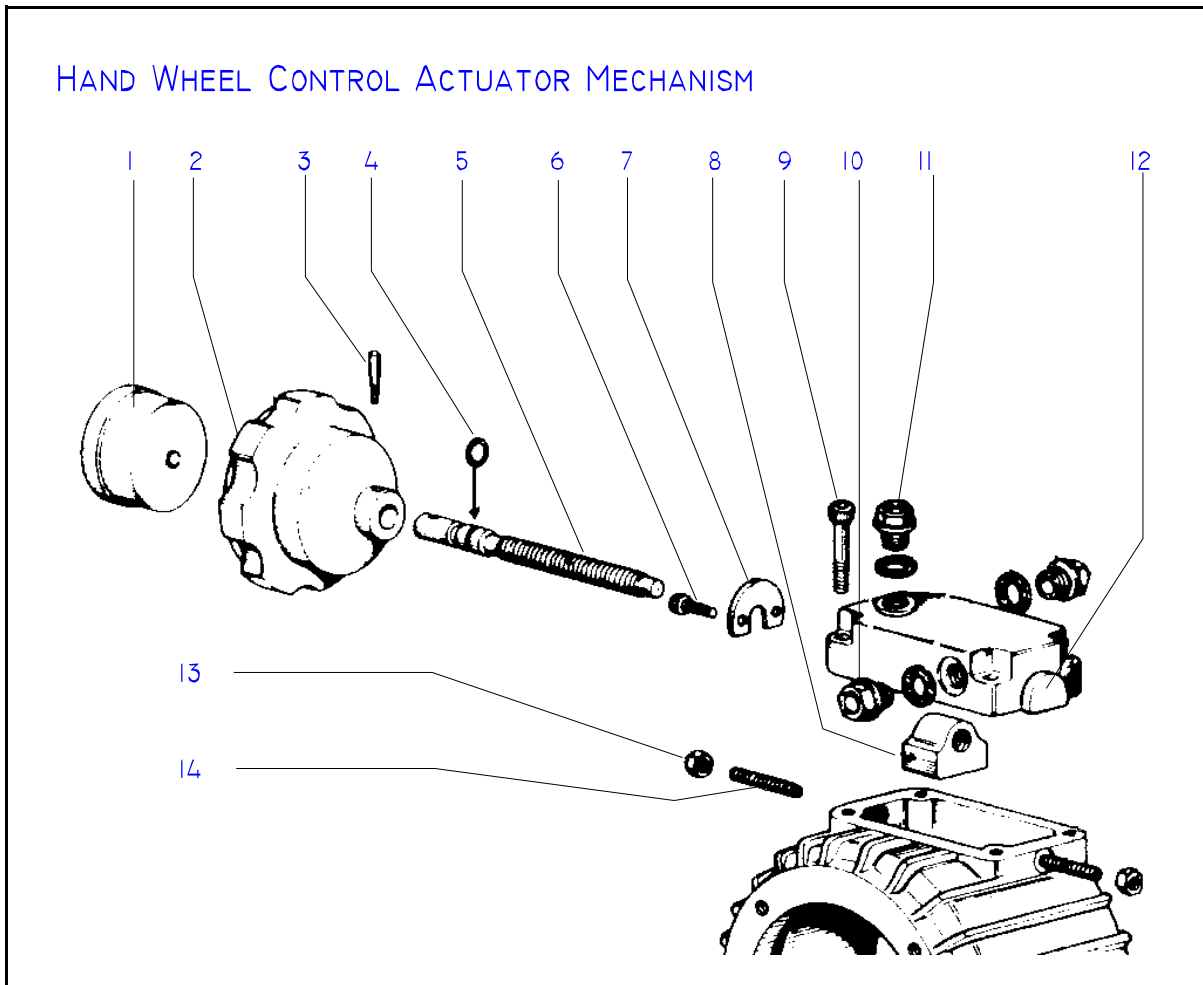

**Figure 10** Discharge Variator Handwheel Control (Exploded View)

# Operating and Maintenance Instructions

---

**Table VI - Key to Figure 10**

---

Item	Description	Item	Description
1	Indicator	8	Control Block
2	Handwheel	9	Socket Screw - control cover
3	Tension Pin - Handwheel	10	Oil Plug
4	O-ring	11	Oil Breather
5	Control Screw	12	Cover - control screw
6	Socket Screw - stop washer	13	Nut - limit stop
7	Stop Washer - control screw	14	Stud Screw - limit stop

---

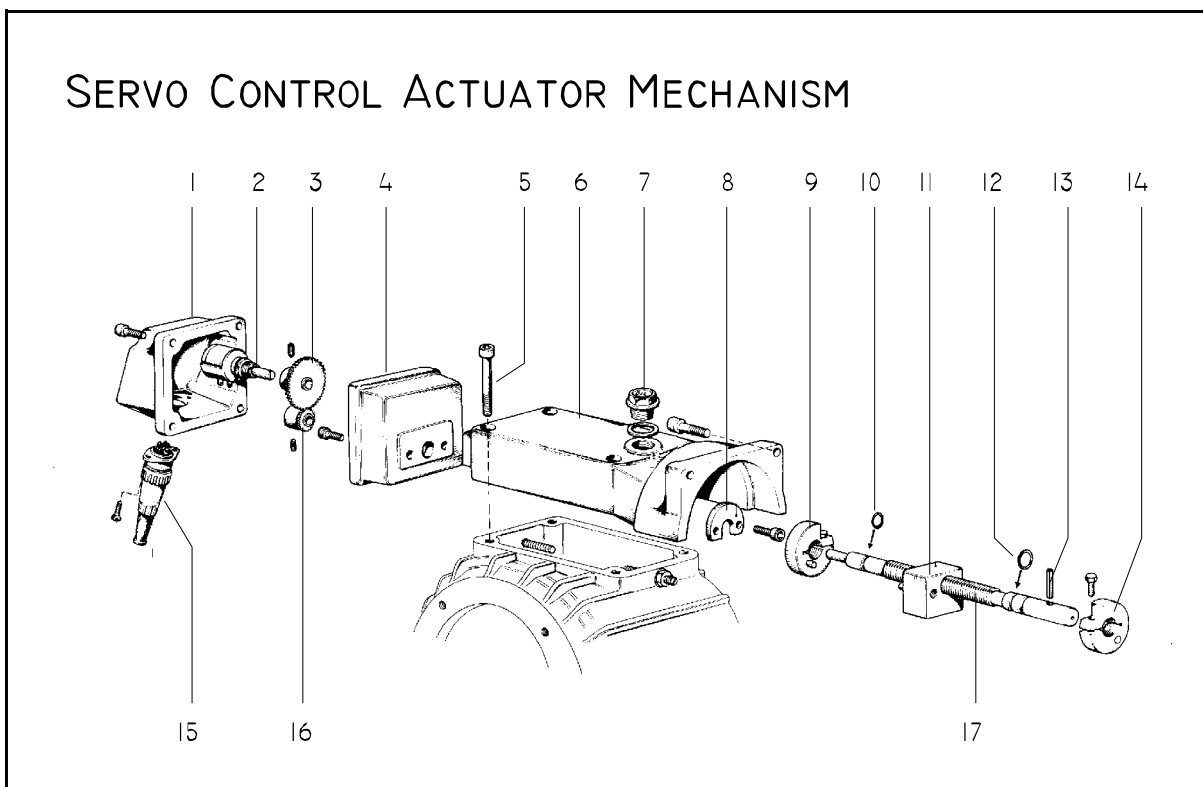

**Figure 11** Discharge Variator Servo Motor (Exploded View)

# Operating and Maintenance Instructions

---

**Table VII - Key to Figure 11**

---

Item	Description	Item	Description
1	Cover	10	O-ring
2	Potentiometer	11	Control Block
3	Driven Gear	12	O-ring
4	Box	13	Spring Pin
5	Control Cover Screw Clamp	14	Adjustment Worm Nut
6	Control Cover	15	Connecting Plug
7	Oil Filler Plug	16	Driving pinion
8	Check Washer Screw	17	Control Screw
9	Adjustment Worm Nut		

---



# Operating and Maintenance Instructions

---

**Table VIII - Key to Figure 12**

Item	Description	Item	Description
1	Clutch Driven Plate	14	Circlip
2	Clutch Disk with Gasket	15	Oil Seal
3	Clutch Disk	16	Motor Flange Connection
4	Clutch Cover Plate	17	Plug
5	Connection Flange	18	Helical Crown
6	Oil Seal	19	Crown Bearing
7	Crown Bearing	20	Oil Seal
8	Reduction Unit Casing	21	Spring Adjustment Rod
9	Filler/Drain Plug	22	Spring Check Bush
10	Worm Bearing	23	Pressure Spring
11	Circlip	24	Bearing Cover Gasket
12	Worm	25	Bearing Cover
13	Worm Bearing		

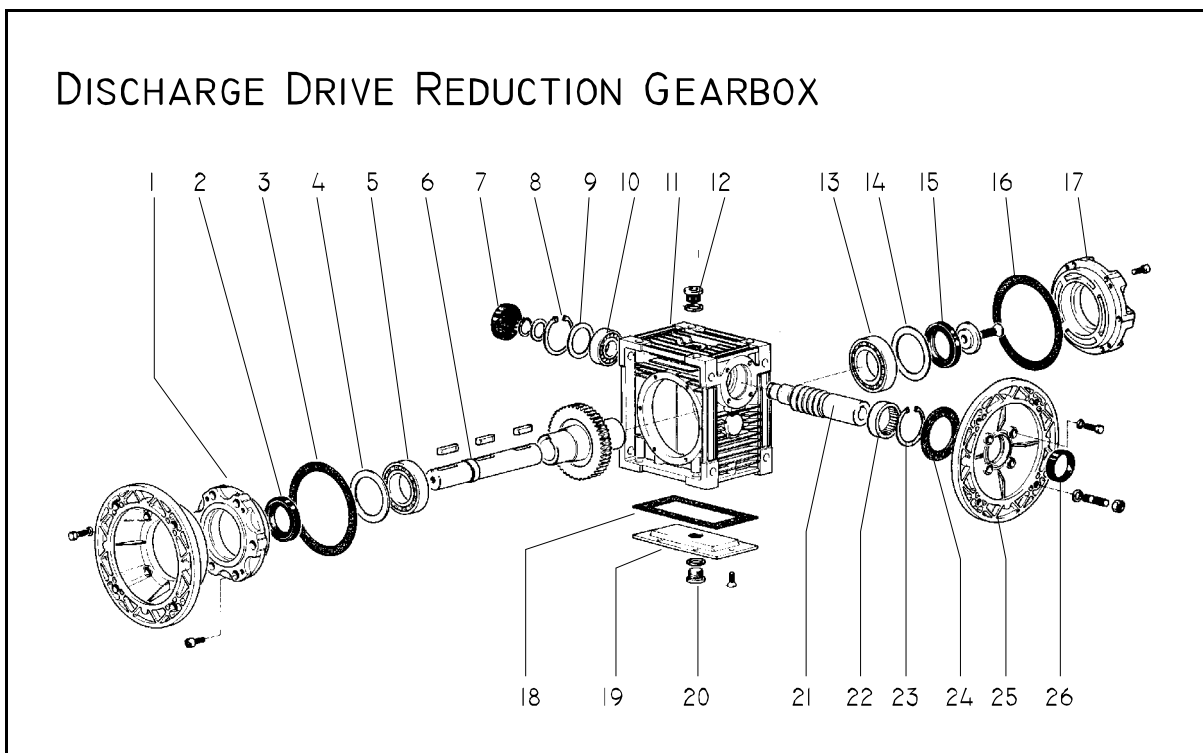

Figure 13 Discharge Reduction Gearbox (Exploded View)

# Operating and Maintenance Instructions

---

**Table IX - Key to Figure 13**

Item	Description	Item	Description
1	Bearing Cover	14	Shim
2	Oil Seal	15	Oil Seal
3	Bearing Cover Gasket	16	Bearing Cover Gasket
4	Shim	17	Bearing Cover
5	Worm Wheel Bearing	18	Casing Cover Gasket
6	Single Output Shaft	19	Casing Cover
7	Plug	20	Filler/Drain Plug
8	Circlip	21	Worm MRV
9	Shim	22	Worm Bearing
10	Worm Bearing	23	Circlip
11	Casing	24	Motor Flange Gasket
12	Filler/Drain Plug	25	Motor Flange
13	Worm Wheel Bearing	26	Oil Seal

---

# Operating and Maintenance Instructions

---

Auto Discharge	20
Automatic	5, 17, 18, 20
Burner	1, 4, 5, 9, 17, 18, 20, 22-24, 26, 28-30
Black Smoke	24
LAL 2.25	4, 22
Lockout	4, 22, 23
Nozzle	1, 24, 28, 29
White Smoke	24
Chaff	26, 30
Control Panel	ii, 1-5, 8, 17, 20, 21, 25, 26, 29, 30
PLC Controller	21
Discharge	2, 4, 5, 10, 13-20, 23, 27, 29, 30, 32
Roller	2, 29, 30
Speed	2, 5, 10, 18-20, 29
Trays	2, 10, 17, 29
Drying Column	1, 2, 4, 17-19, 26, 28, 30
Empty	1, 4, 17, 23
Fans	17, 18, 26, 30
Feed-on-Demand	17
Fill	17
Fuel Leaks	9, 30
Fuel Pump	9
Fuel Tank	8
Furnace	1, 26, 28
Germination	
Malting Barley	7
Seed	5, 7, 30
Grain	1, ii, 1, 2, 4, 5, 7-9, 17-21, 23, 25, 26, 28, 29
Grain Temperature	
Germination	6
Holding Section	1, 4, 18
Low Volume Ventilation	2
Manual	i, 4, 17, 18, 24
Moisture Content	17-20
Input Moisture Content	19, 20
Output Moisture Content	17-20
Wet Grain	1, 17, 18, 23
Oil	1, 4, 7, 9, 18, 20, 24, 27-30, 33, 35, 37, 39, 41
Lubrication	27, 28
Nozzle	1, 24, 28, 29
Oil Filter	9, 24
Proximity Switch	1, 4, 18
Push-button	
Start	1, 17, 21-23
Stop	17, 19, 23, 26, 33, 35
Recirculate	17, 18
Shutdown	4, 5, 17, 18, 20-22
Straw	29, 30
Temperature	1, 2, 4-8, 17-20, 23, 27-30
Air Temperature	2, 4, 6, 7, 17, 19, 23, 30

# Operating and Maintenance Instructions

---

Grain Temperature .....	2, 4, 7, 18, 23
Overheat .....	4, 23, 26
Variator .....	27, 32, 33
running temperature .....	27