

CONTINUOUS MIXED FLOW GRAIN DRYERS

Dryer Assembly Instructions

© 1990,1992,1994 Kentra Grain Systems Limited - All Rights Reserved



Assembly Instructions

Table of Contents

Preface	iv
Dryer Foundation	iv
Dryer Assembly	iv
1. Discharge Unit	1
2. Drying Column and Exhaust Plenum	2
a. Drying Column Assembly	2
b. Exhaust Plenum	4
3. Inlet Plenum and Furnace Assembly	7
a. Inlet Plenum	7
b. Furnace Unit	9
4. Temperature Probes	14
5. Proximity Switches	16
a. Reserve Section	16
b. Discharge Hopper	16
6. Pre-commissioning Checks	18
a. Electrical Inspection (Before Mains Power is Applied)	18
b. Electrical Inspection (After Mains Power is Applied)	18
c. Fuel Supply Inspection and Installation	18
d. Discharge Unit Inspection	19
e. Dryer Inspection	20
Index	21

Assembly Instructions

Figures

Figure 1 - Positioning Discharge Unit	1
Figure 2 - Type 25 Drying Zone Exhaust Side	2
Figure 3 - Type 25 Drying Zone Inlet Side	2
Figure 4 - Discharge Unit and Column (Dryer Model 1125)	3
Figure 5 - Zone Corner Support Angle	4
Figure 6 - Fan Support and Plenum Corner Bracing Angle Positions	4
Figure 7 - Exhaust Plenum Assembly (Dryer Model 1125)	6
Figure 8 - Control Linkage Arrangement for adjustable cooling (Model 1325 shown)	7
Figure 9 - Inlet Plenum up to level of Mixing Chamber (Dryer Model 1125)	8
Figure 10 - Furnace Inlet Restrictor Plate Position	9
Figure 11 - Position of Furnace Assembly (Dryer Model 1125)	11
Figure 12 - Furnace Heat Exchanger Placement (Dryer Model 1125)	12
Figure 13 - Completed Furnace Mixing Chamber (Dryer Model 1125)	13
Figure 14 - Position of Hot Air PT100 Ω Temperature Probe	14
Figure 15 - Position of Auto Discharge and Hot Grain PT100 Ω Temperature Probes	15
Figure 16 - PX2 Proximity Switch Positions	16
Figure 17 - Burner Oil Supply Line	17

Assembly Instructions

Preface

The Kentra dryer has been designed for ease of installation, with as many parts as possible being sent from the factory pre-assembled. Before starting to erect the dryer please check and familiarise yourself with all the component parts by referring to the packing list supplied.

Dryer Foundation

It is essential that the dryer is erected onto a suitably firm and level concrete foundation. If the dryer is to be erected out of doors the foundation must be designed in accordance with the following British Standard: BS. 449, PART 1, 1970, CP3 CHAPTER V, PART 2, 1970 and the advice of a local consultant engineer should be sought. If "drill-through" holding down bolts are used instead of grouted-in bolts you must ensure that they are capable of withstanding the very high pull-out forces which are unavoidable on tall outdoor dryers.

Dryer Assembly

Throughout this manual reference is made to the assembly of a dryer model 1125. The basic principles are the same for all models of dryer throughout the range. Reference to both the arrangement drawing and packing list supplied with your dryer will show the particular differences.

Assembly is started by placing the dryer discharge unit onto the prepared foundation taking particular care to ensure that the top flange is absolutely level in both directions. Adjustments can be made by packing under the dryer base plates as required.

Following the installation of the discharge the drying zones are then lifted into position and bolted together, followed by the exhaust plenum chamber, inlet plenum chamber and finally furnace and furnace mixing chamber. All external joints should be sealed with the sealant strip supplied.

After completing assembly, both the dryer and surrounding area should be carefully checked to ensure that all tools, nuts, bolts, etc. have been cleared away.

Assembly Instructions

THIS PAGE IS INTENTIONALLY BLANK

Assembly Instructions

1. Discharge Unit

The discharge unit is lifted into position onto the prepared foundation as shown in **Figure 1** taking particular care to ensure that the top flanges are level in both directions. Any necessary adjustments can be made by packing under the discharge leg footplates with metal strips. After levelling the discharge unit it should be securely fastened to the holding down bolts.

It is essential to position the discharge unit with the drive motor on the furnace side of the dryer. This will also assist the electrician when he comes to route his cables.

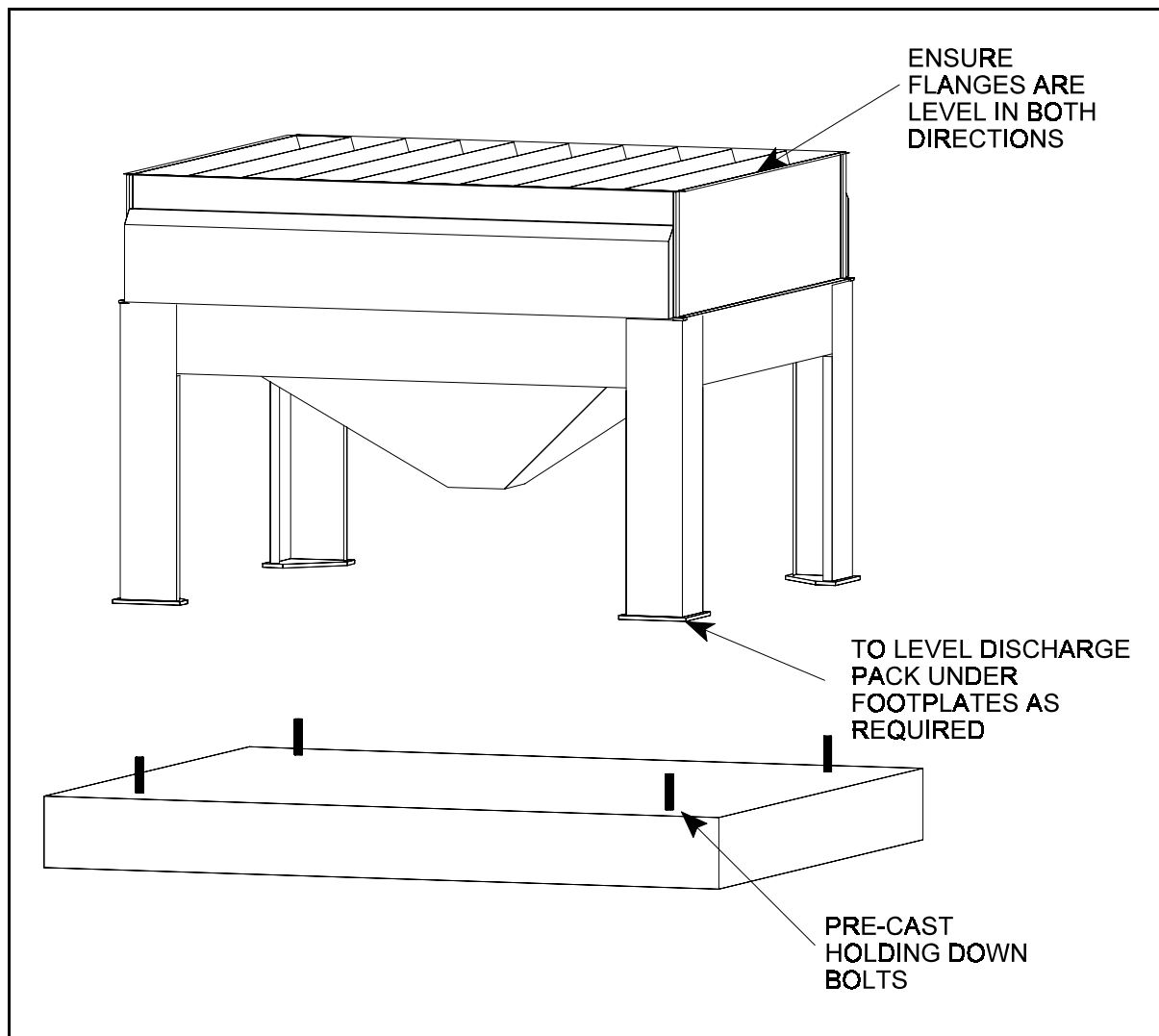

Figure 1 - Positioning Discharge Unit

Assembly Instructions

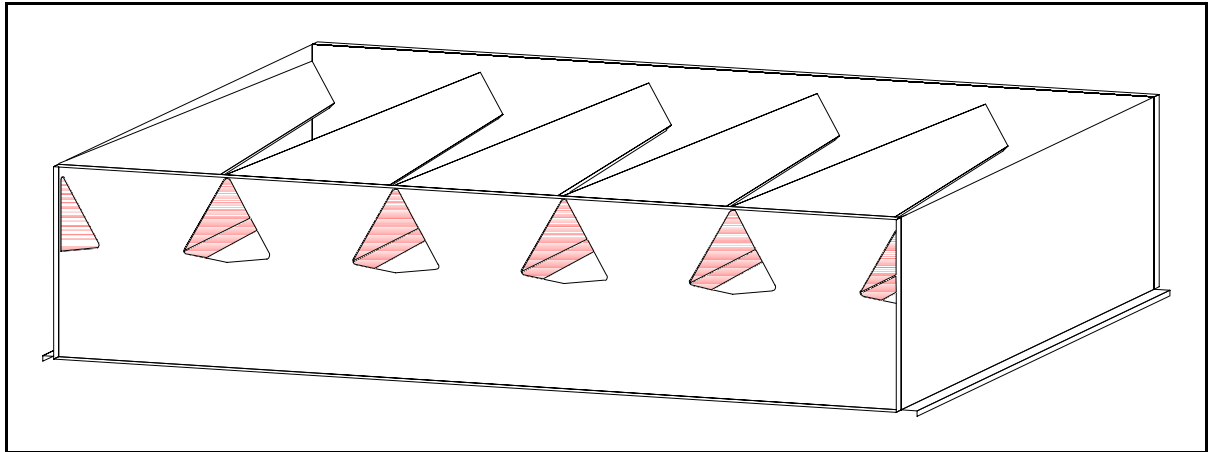

Figure 2 - Type 25 Drying Zone Exhaust Side

2. Drying Column and Exhaust Plenum

a. Drying Column Assembly

All the drying zones are fitted with two half ducts on the exhaust (Fan) side of the dryer (See **Figure 2** and **Figure 3**), and are marked as such when they are dispatched from our factory. It is imperative that the drying zones are positioned correctly with the exhaust side facing towards the fan side of the dryer.

All the drying zones can now be lifted into position. If suitable lifting equipment is available then the drying zones can be bolted together in groups of up to four units at ground level prior to lifting into place. (See **Figure 4**, page 3)

When all the drying zones have been lifted into position the Reserve Section can be lifted into position. Please ensure that all external joints have been adequately sealed before lifting the reserve section into place.

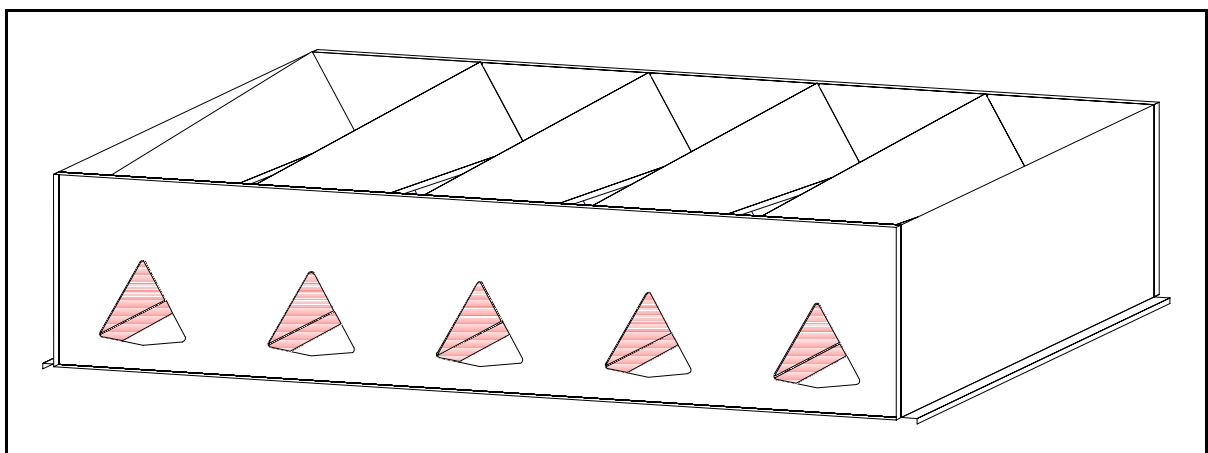

Figure 3 - Type 25 Drying Zone Inlet Side

Assembly Instructions

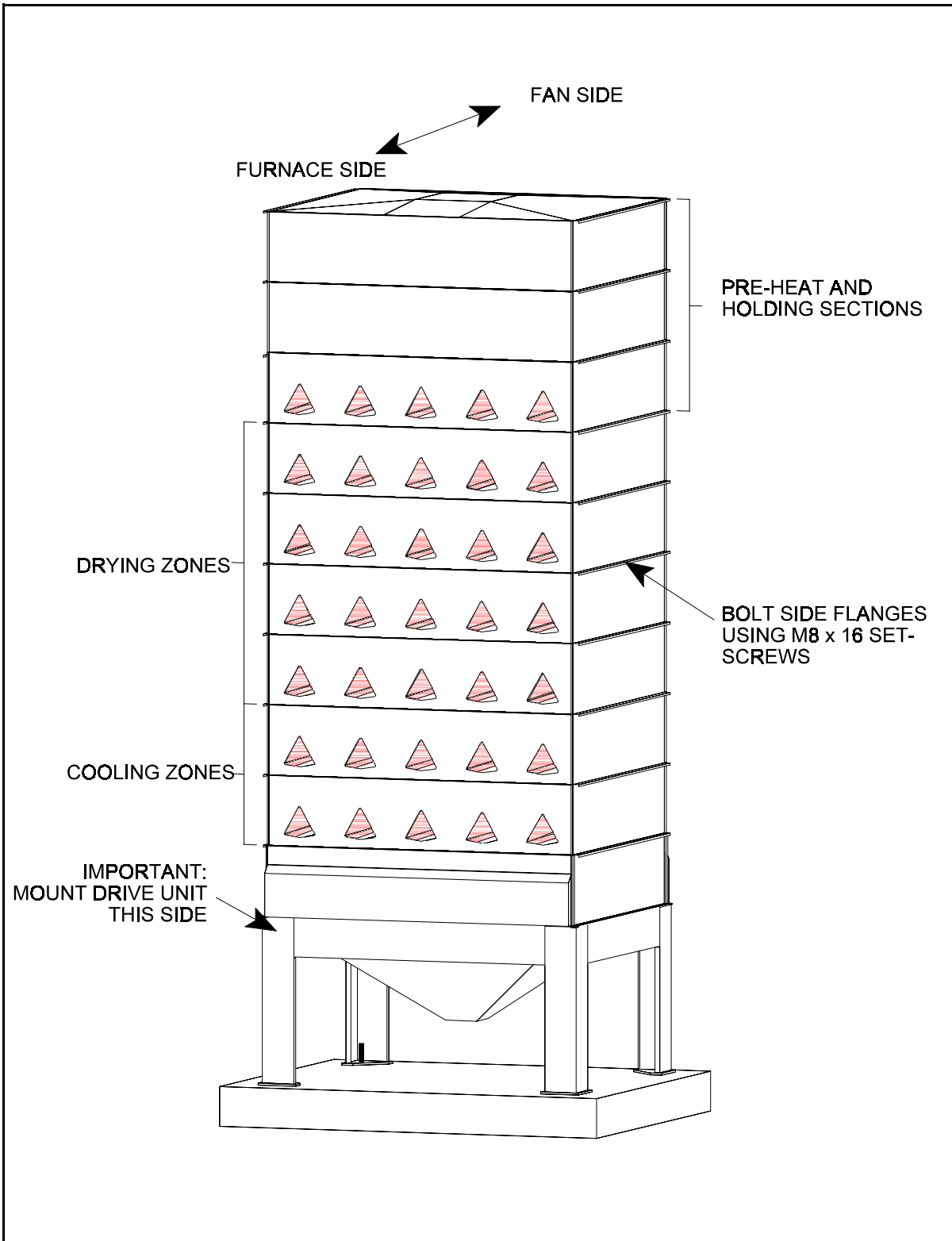

Figure 4 - Discharge Unit and Column (Dryer Model 1125)

Assembly Instructions

b. Exhaust Plenum

After building the dryer column and reserve section the next stage is to assemble the dryer exhaust plenum. All the horizontal and vertical joints on the exhaust plenum are assembled with M8 x 16 setscrews apart from the vertical connection to the drying zone which is assembled with M8 x 25 setscrews.

The procedure for building the plenums on a Type 40 & 50 dryers is identical with the exception that it is necessary to fit joint support channels (supplied) on the centre horizontal joints.

Start by bolting the two plenum roof/base side panels (#8010073) onto the bottom drying zone, not forgetting to seal the vertical joint between the panel and the drying column. Do not forget to fit the zone corner support angle (See **Figure 5**) bolting at the top and bottom as well as the side. Next fit the plenum roof/base front panel (#8010083) as shown in **Figure 7** on page 6. After fitting these items continue to build the remainder of the plenum, the position of the fan connection panels can be found by referring to the general arrangement drawing for your particular model of dryer at the rear of this manual. Under certain circumstances the position of the fan(s) can be moved from the normal position. However, if you are not sure please contact us for advice.

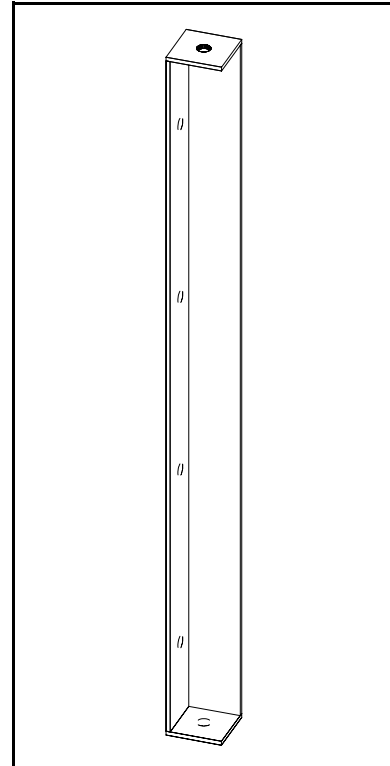

Figure 5 - Zone Corner Support Angle

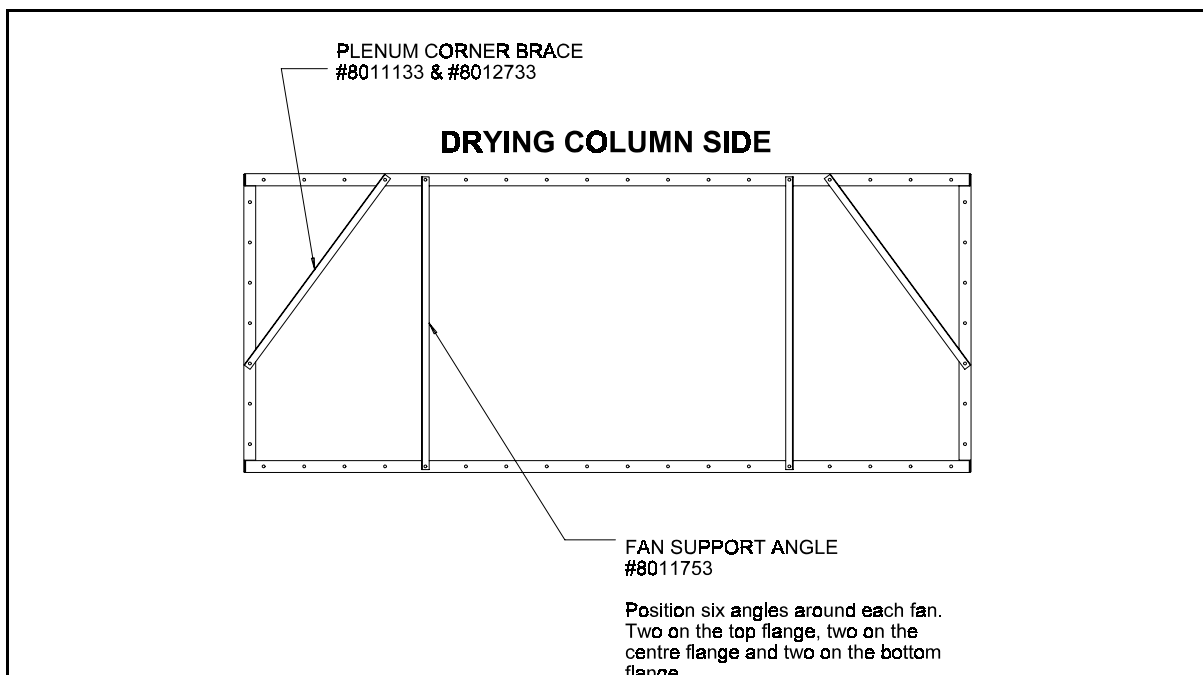

Figure 6 - Fan Support and Plenum Corner Bracing Angle Positions

Assembly Instructions

It is recommended that all the bolts are left loose until all the panels are in place, and then tightened.

Please refer to **Figure 6** for the correct position of the plenum corner bracing angles (#8011113) and the fan support angles (#8011153).

After completing the assembly of the exhaust plenum sides and front, the roof panel (#8010063) can be lifted into position, sealed with the sealant strip supplied and bolted. The plenum base plate which includes the air control slides should be left out until the dryer is finished as it improves your access into the plenum by not fitting it at this stage.

Assembly Instructions

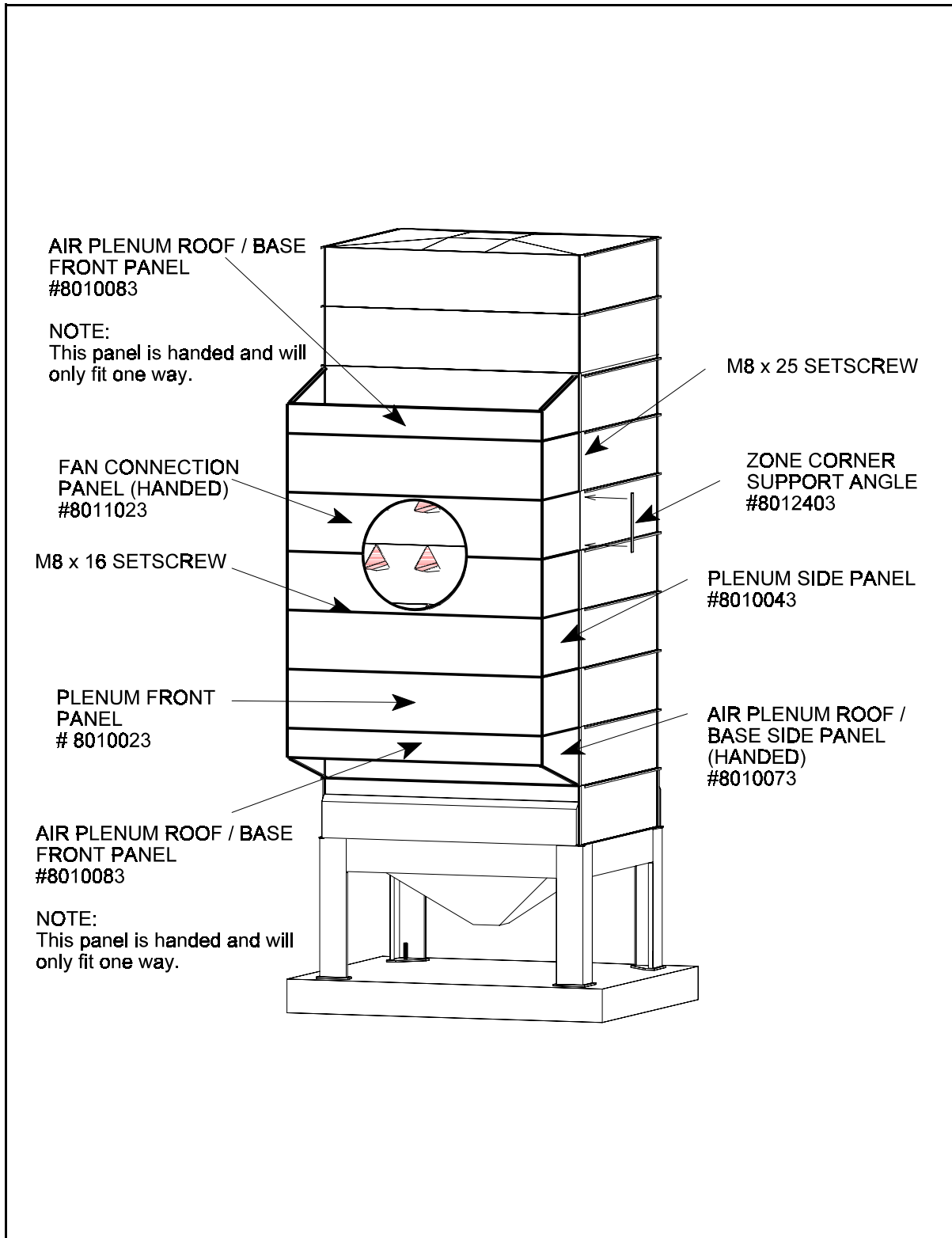

Figure 7 - Exhaust Plenum Assembly (Dryer Model 1125)

Assembly Instructions

3. Inlet Plenum and Furnace Assembly

a. Inlet Plenum

After completing assembly of the exhaust plenum the next stage is to build the inlet plenum and furnace unit. Start by building the inlet plenum in the same way as the exhaust plenum up to the start of the furnace mixing chamber (See **Figure 9**, Page 8). The level for your

particular model of dryer can be found by referring to the general arrangement drawing supplied with this manual. You can also at this stage fit the cooling floor plates (#8011143) which sit on top of the plenum panel horizontal flanges. Again, referring to the arrangement drawing will indicate the position of the cooling floor plates.

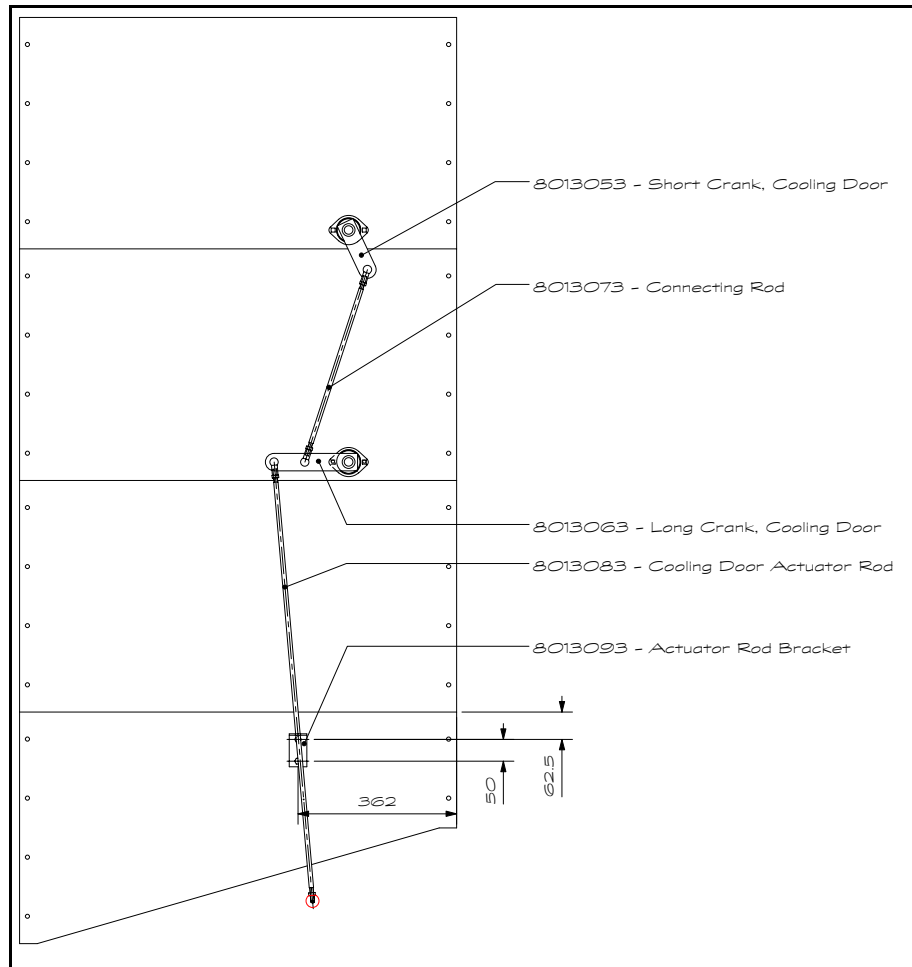

When fitting the control linkage for remote operation of the cooling doors it will be necessary to drill the plenum side to accept the actuator rod bracket in the position shown in figure 8.

It is not necessary to fit the plenum corner bracing angles here as the cooling floor plates perform the same function of stiffening the plenum and keeping it square.

Please note that the corners of the cooling floor plates are notched. The wider notch fits into the corner adjacent to the drying column.

Assembly Instructions

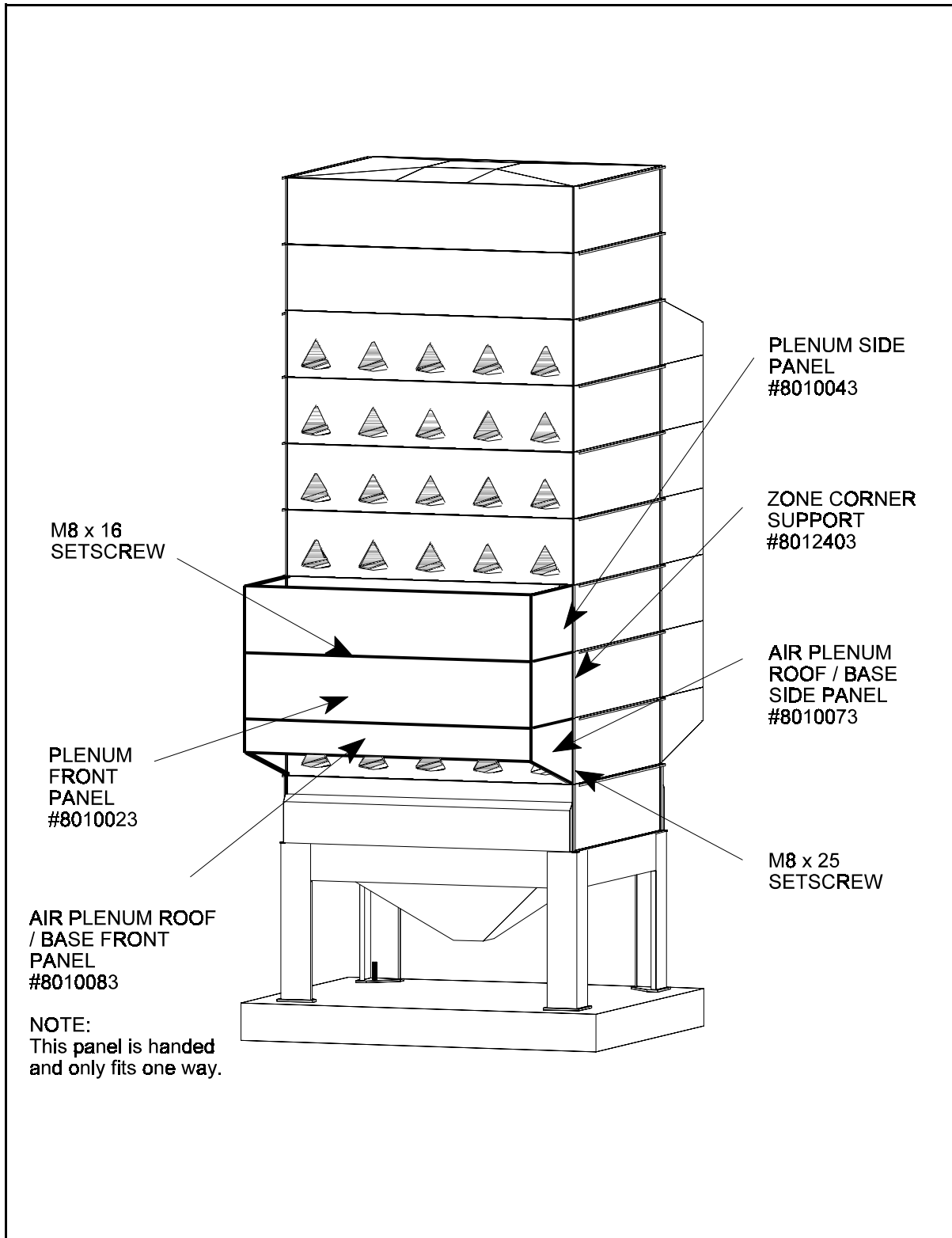

Figure 9 - Inlet Plenum up to level of Mixing Chamber (Dryer Model 1125)

Assembly Instructions

b. Furnace Unit

The next stage is to position the furnace assembly. This is a free standing unit and should be placed centrally tight up against the plenum front plates (See **Figure 11**, Page 11). After positioning the furnace check that it is level and square, this is very important because if the furnace is not level and square it may be impossible to open the furnace access door.

After positioning the furnace the remainder of the inlet plenum can be assembled along with the side plates for the furnace mixing chamber. Again, please refer to the general assembly drawing for your particular model to determine the position of the panels.

It is important to note the inlet from the furnace to the inlet plenum. This is achieved by leaving out the plenum front panels (#8010023) at the appropriate place. In the case of the dryer model 1125 shown in **Figure 12** only one panel needs to be left out. However, on the larger dryers more than one panel will need to be omitted, please refer to the general arrangement drawing to see which panels need to be left out and their position. It will be necessary to fit some plenum corner bracing angles at this point to maintain the stiffness of the plenum. Type 40 & 50 dryers are supplied with a vertical support which is fitted in the centre of the opening to carry the weight of the panels above.

After building the side panels of the furnace mixing chamber the next stage is to lift into position the furnace heat exchanger (See **Figure 12**, page 12). The furnace heat exchanger sits directly on top of the furnace housing and is located on to the combustion chamber by means of a circular spigot. Before lifting the heat exchanger into position please ensure that the combustion chamber is sat squarely on its four support brackets.

Some Type 40 and 50 dryers incorporate restrictor plates in the mixing chamber around the heat distribution arms. The purpose of these plates is to reduce the size of the air inlet around the heat distribution arms. The panels to which they are fixed will require drilling on site as

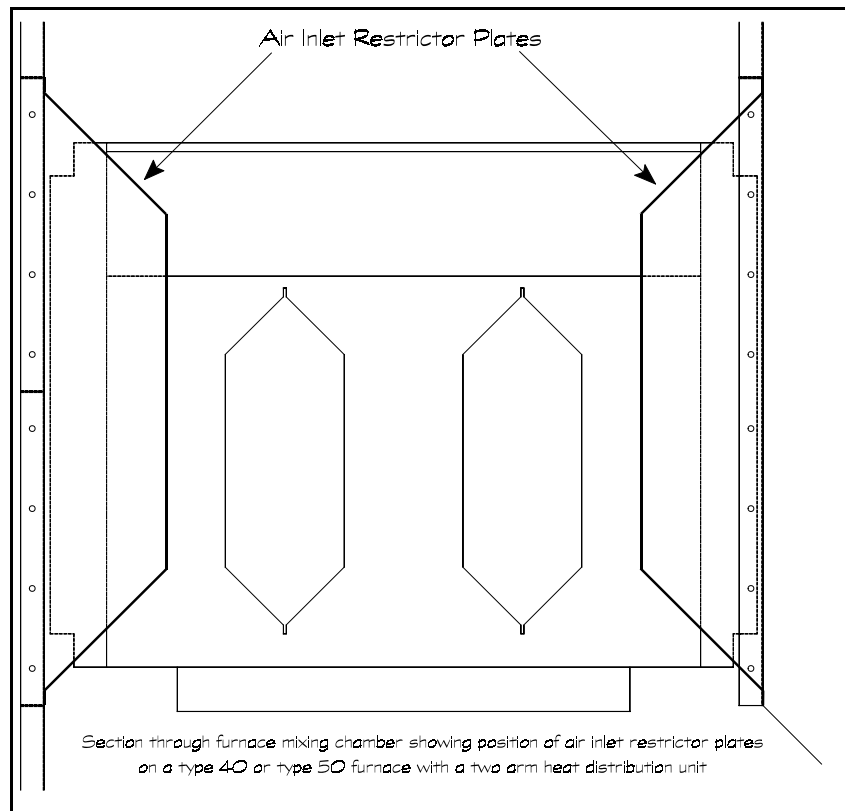

Figure 10 - Furnace Inlet Restrictor Plate Position

Assembly Instructions

required.

Figure 13 on page 13 shows the completed inlet plenum and furnace, at this point check all the joints to make sure they are weather tight and tighten all the nuts and bolts.

If you have not already done so you can now lift and bolt the fans into position, together with their silencers if supplied.

Assembly Instructions

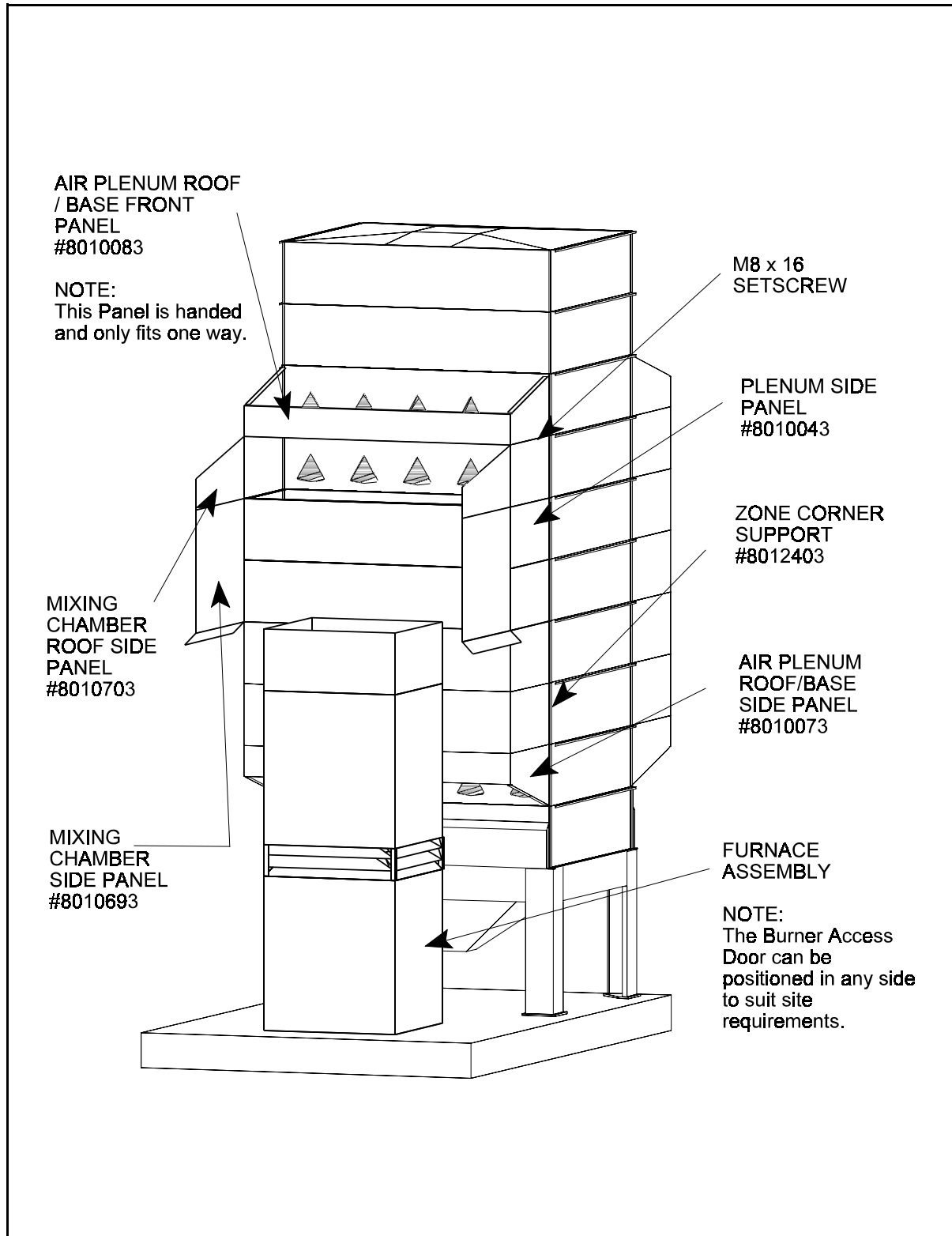

Figure 11 - Position of Furnace Assembly (Dryer Model 1125)

Assembly Instructions

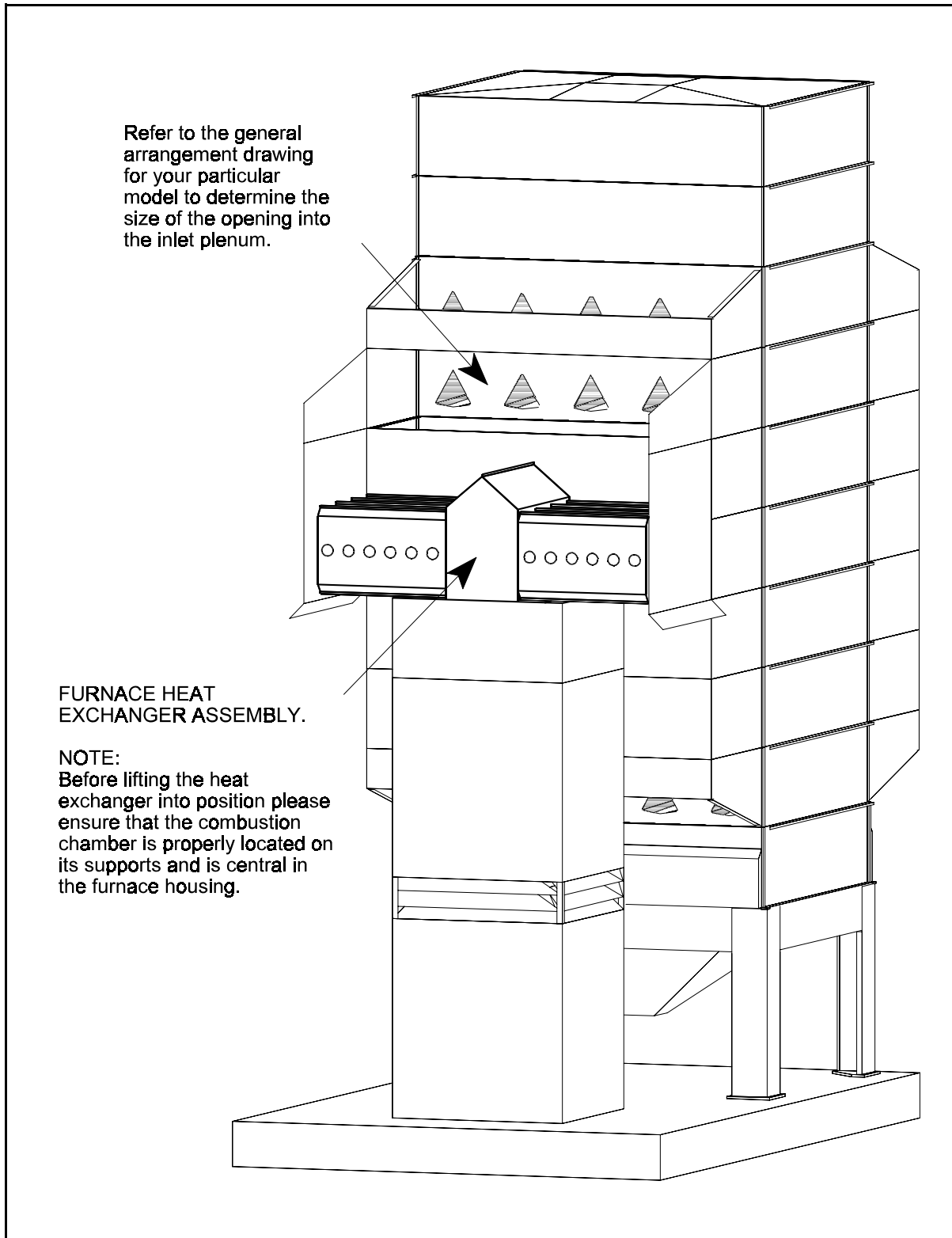

Figure 12 - Furnace Heat Exchanger Placement (Dryer Model 1125)

Assembly Instructions

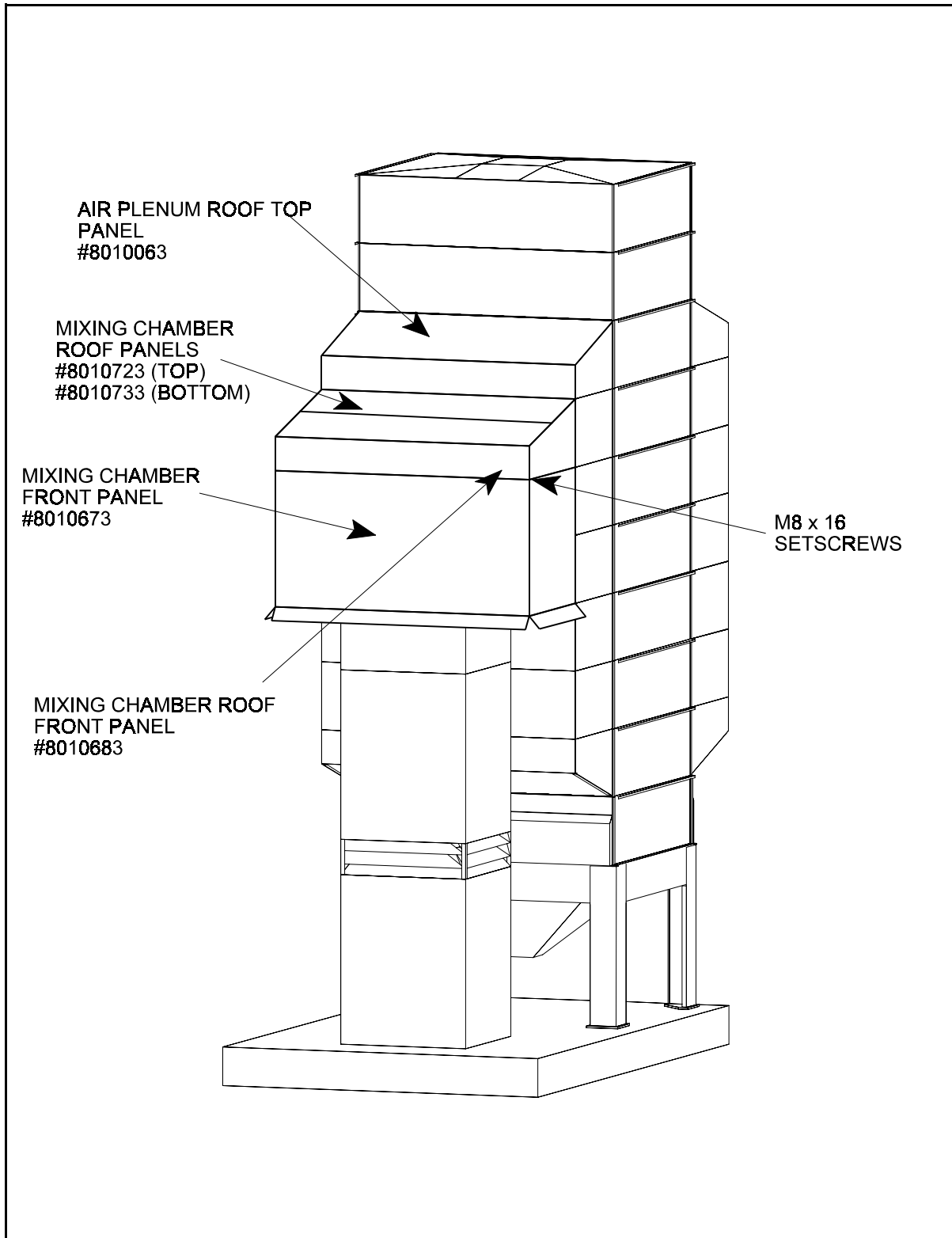

Figure 13 - Completed Furnace Mixing Chamber (Dryer Model 1125)

Assembly Instructions

4. Temperature Probes

The temperature probes supplied are a type PT100Ω. The probes should be fastened to the bracket supplied using the cable grip supplied and mounted as shown in **Figure 14** and **Figure 15**. The positions of the probes for each particular model of dryer can be found by referring to the relevant general arrangement drawing.

Each temperature probe is supplied with sufficient length of heat resistant cable for connection **outside** of the plenum using a suitable water and dust-proof junction box. When wiring the probes please leave a loop of cable at the probe in case adjustment is required after operating the dryer.

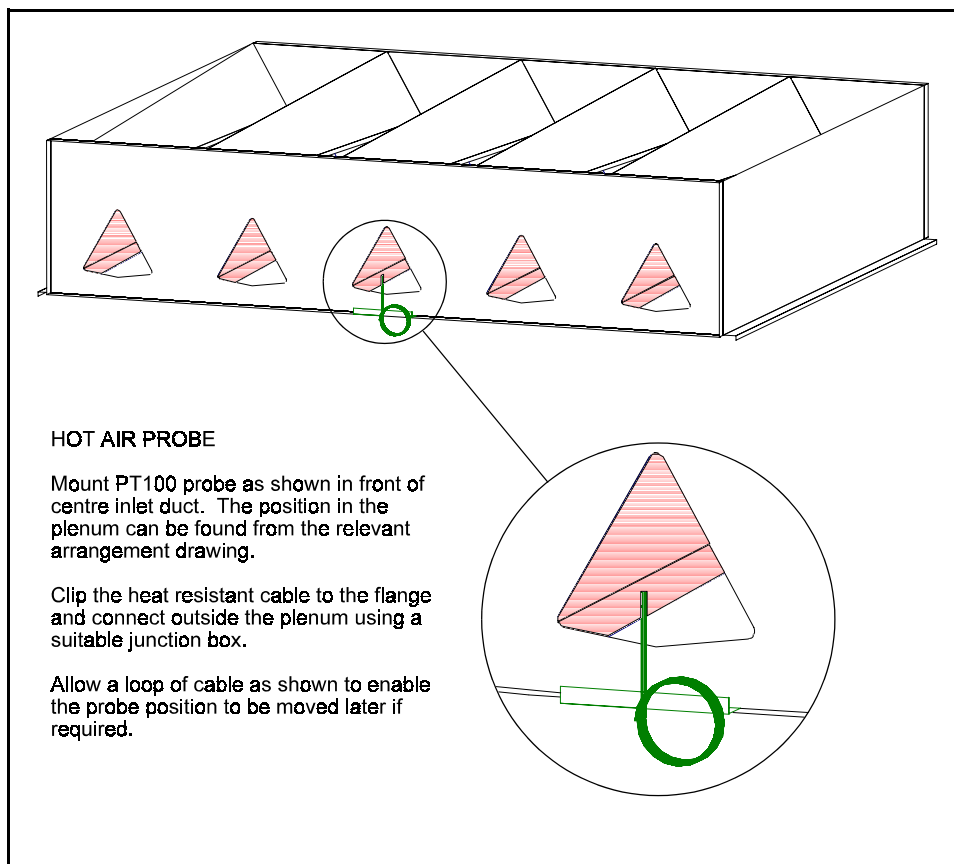

Figure 14 - Position of Auto Discharge and Hot Grain PT100Ω Temperature Probes

Assembly Instructions

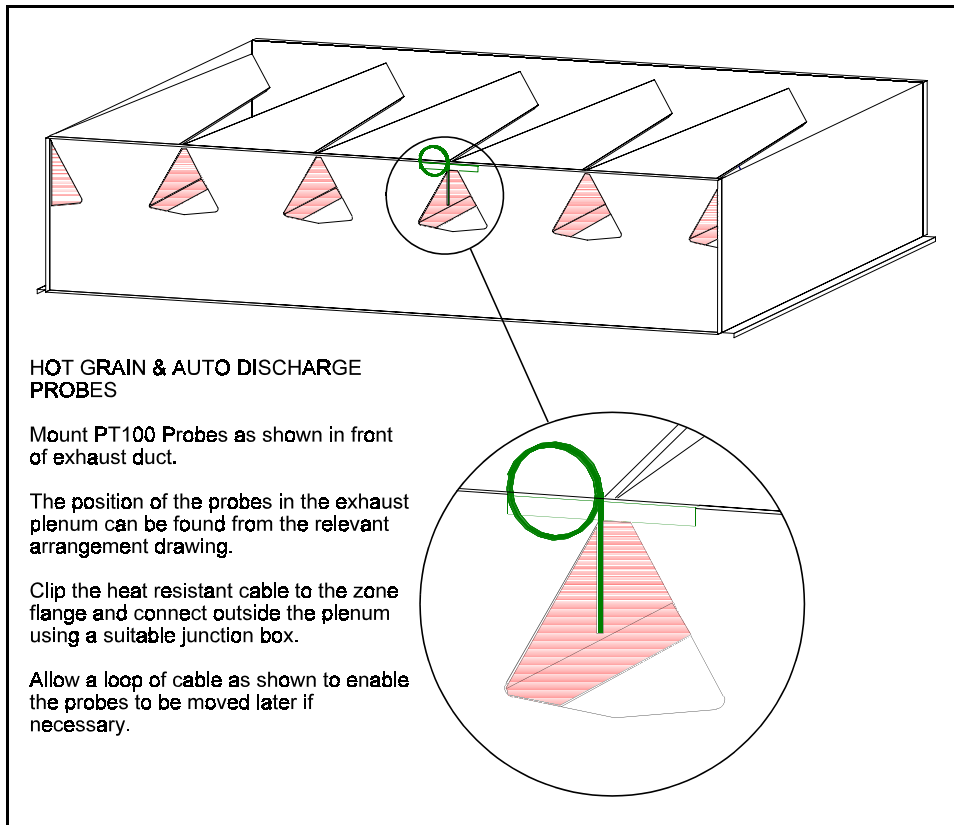

Figure 15 - Position of Auto Discharge and Hot Grain PT100 Ω Temperature Probes

Assembly Instructions

5. Proximity Switches

a. Reserve Section

As standard the dryer is supplied with one type PX2 proximity switch for the reserve section which senses when the dryer runs out of grain. In addition, if the dryer is supplied for Feed on Demand, a further two switches will be supplied for fitting in the reserve section. To fit the switches it is necessary to drill a 50mm hole in the side of the reserve section for each probe using a suitable hole cutter. The drilling positions are shown in **Figure 16**.

b. Discharge Hopper

To prevent blockage of the discharge mechanism due to failure of equipment after the dryer each discharge hopper is fitted with a PX2 proximity switch. These switches should be fitted into the 50mm dia. hole adjacent to the hopper access hatch.

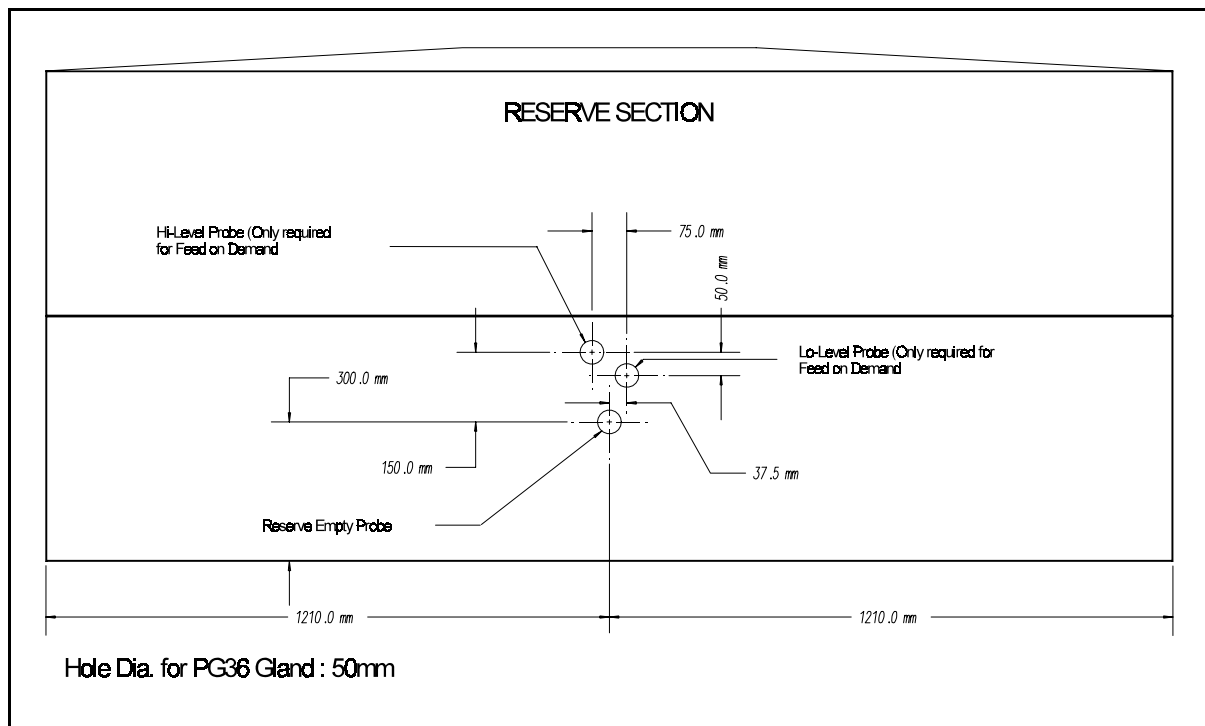

Figure 16 - PX2 Proximity Switch Positions

Assembly Instructions

DRYER MODELS	2506 - 2507	2509 - 2510	2512 - 2517	5006 - 5012	5013 - 5017
PIPE DIAMETER	ID 15 1/2"	ID 20 3/4"	ID 25 1"	ID 25 1"	ID 32 1 1/4"
The pipe diameters shown in the table above are suitable for an equivalent STRAIGHT flow pipe length of 15.0 metres. A 90° elbow is equivalent to 0.5 metre of straight. If the total equivalent length exceeds 15.0 metres please contact us for advice.					

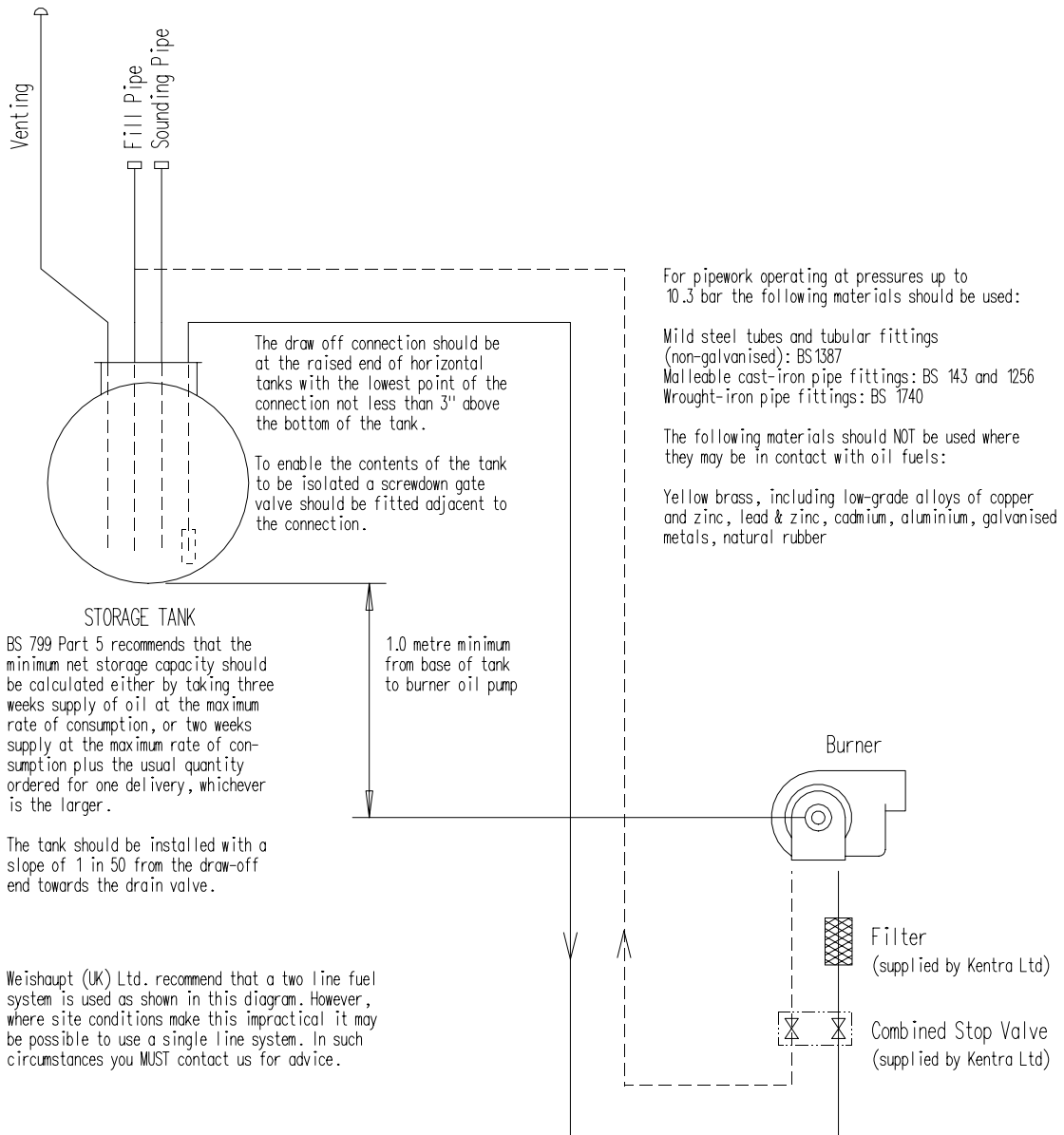

Figure 17 - Burner Oil Supply Line

Assembly Instructions

6. Pre-commissioning Checks

Before using your KENTRA Dryer for the first time it is essential that you have the following checks carried out to ensure that your new Dryer is ready to be put into operation. Certain of these checks must only be carried out by qualified personnel (e.g. Electrical Checks) and are marked as such where necessary.

a. Electrical Inspection (Before Mains Power is Applied)

The following checks are to be performed only by suitably qualified personnel.

- i. The Control Panel should be firmly fixed to a secure wall and should be connected to a suitably sized and protected Mains Supply.
- ii. All Electrical Connections on both the Dryer and the Control Panel Terminal Rail should be thoroughly checked for good connection and tightness.
- iii. All Cables from the Dryer Control Panel should be checked for continuity. Take care when doing this as there are sensitive electronic devices within the Control Panel. If you are in any doubt contact KENTRA Limited.
- iv. Ensure that all Earth Connections are tight and if any RCCBs or ELCBs are fitted make sure that they function correctly.
- v. Check and set the Overload Relays within the Control Panel, check the individual Motor Serial Plates for the correct FLC Values.
- vi. Thoroughly clean the inside of the Control Panel paying particular attention to loose strands of cable and drilling swarf which may contaminate the Relay Contacts causing failure. Such damage is not covered under Warranty!!!

b. Electrical Inspection (After Mains Power is Applied)

The following checks are to be performed only by suitably qualified personnel.

- i. Check for correct operation of all Temperature Controllers and Indicators.
- ii. Check that all Proximity Switches function correctly.
- iii. Check all Electric Motors for correct rotation and adjust where necessary.
- iv. Check that each Electric Motor's running current does not exceed the FLC shown on the Motor Rating Plate.

c. Fuel Supply Inspection and Installation (see **Figure 17**)

- i. The Fuel Tank should be positioned so that the tank outlet is level with or above the level of the Oil Burner Fuel Pump. If this is not the case contact KENTRA Limited for advise.

Assembly Instructions

- ii. The Supply Line from the Tank to the Oil Burner must be installed with proper levels for a gravity system without air pockets.
- iii. The Supply Line must be free of fuel leaks and there must be no air leaks.
- iv. Any additional filters or strainers fitted to the fuel supply line must not impede the fuel flow.
- v. Termination of the oil supply pipe(s) must allow tension free connection of the flexible oil hoses. Both oil and electrical connections must allow the burner to swing open.
- vi. The oil filter supplied must be installed to protect the burner fuel pump and system, and should be mounted at the termination of the oil supply to the burner.

The following faults can occur if a filter is not fitted.

- Seizing of the pump drive
- Blocking of solenoid valves and nozzles

YOU HAVE BEEN WARNED!!!

- vii. The flexible hoses supplied with the burner are of a high quality and covered with a woven wire sleeve cover. Properly installed they will give years of trouble free service. When installing care must be taken to ensure that the hose is not twisted. In order to guarantee strain free installation the hose should first be loosely fixed at one end, then moved through the required hose movement 2 to 3 times, so that the hose can align without distortion, and then tighten in position.

A second spanner must be used to counter hold when tightening. Particular care should be taken that the hoses do not foul each other or other equipment during operation. The hose connections can be installed for either burner hinge direction as required.

d. Discharge Unit Inspection

- i. The discharge unit must be checked to ensure that there is no debris in the unit. (nuts, bolts, etc. left over from installation)
- ii. The rollers must be checked for correct direction of rotation. This is most important as serious damage could result if the rollers are allowed to rotate in the wrong direction.

Assembly Instructions

- iii. The chain drive must be checked for correct tension and lubricated, and the variable speed drive unit must be operated throughout its entire speed range.
- iv. The discharge trays must be checked for free movement using the wrench provided. The gas springs require quite a large effort to move them but there should be no tight spots through the full travel of the tray lever.

e. Dryer Inspection

- i. Check that, where necessary, all access doors are securely fastened.
- ii. Check that all air control slides are free to operate and adjust where necessary.
- iii. If the Dryer is erected outside make sure that all the holding down bolts are secure and properly tightened.
- iv. Finally check thoroughly around the Dryer to make sure that all bolts are tight and that all erection debris, such as nuts, bolts, etc., has been cleared up.

Assembly Instructions

Index

Auto Discharge (15)
Burner (17-19)
Control Panel (18)
Discharge (iv, 1, 3, 15, 16, 19, 20)
 Speed (20)
 Trays (20)
Drying Column (2, 4, 7)
Fans (10)
Fuel Leaks (19)
Fuel Pump (18, 19)
Fuel Tank (18)
Furnace (iv, 1, 7, 9-13)
Grain (1, 15, 16)
Manual (iv, 7)
Oil (17-19)
 Oil Filter (19)
Proximity Switch (16)
Push-button
 Start (4, 7)
Temperature (14, 15, 18)